

V1.0

Using a 32-bit motor driver chip and Field-Oriented Control (FOC), the RoboMaster G200 Brushless DC Motor Speed Controller enables precise control over motor torque.



Customized designed for the RoboMaster G200's PMSM Brushless DC Motor and G200 Brushless DC Motor Speed Controller, this 32-bit Assorted ICs includes several ICs and a terminal board.

Reference System Specification Manual, Reference System User Manual, Introduction of Reference System Module



See M009 Assorted ICs include several ICs and a terminal board, covering a complete protection system for their reference system.



ROBOMASTER

ROBOMASTER 2021

UNIVERSITY CHAMPIONSHIP

RULES MANUAL

Prepared by the RoboMaster Organizing Committee
Released on October 2020

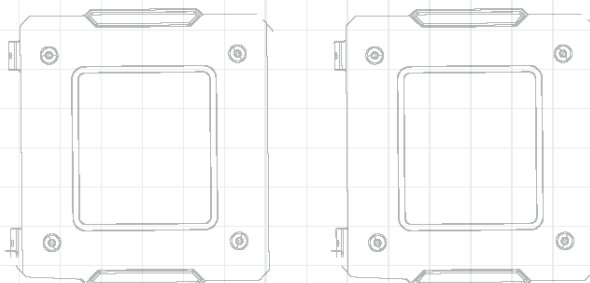

Intellectual Property Statement

The RoboMaster Organizing Committee (hereinafter referred to as "the RMOC") encourages and advocates for technological innovation and open source technology and respects the intellectual property of participating teams. All rights related to the intellectual property developed during the competition are owned by the individual teams. The RMOC will not be involved in the handling of intellectual property disputes within teams. The participating teams must properly handle all aspects of intellectual property rights among internal school members, company members and other members of the team.

While using the RoboMaster Referee System and other supporting materials provided by the RMOC, teams should respect the owners of all intellectual property. Teams are also prohibited from engaging in any behavior that violates intellectual property rights, including but not limited to reverse engineering, replication or translation.

With regard to any behavior that may infringe upon the intellectual property rights relating to educational materials provided for the competition by the RMOC or co-organizers, the intellectual property rights owners are entitled to hold the infringing parties responsible in accordance with law.



Relevant suggestions for open source materials can be found in this link: <https://bbs.robomaster.com/thread-7026-1-1.html>.

Reading Tips

Legend

 Prohibitions	 Important notes	 Hints and tips	 Definitions and references
--	---	--	--

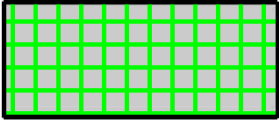
Legend for Battlefield Drawings

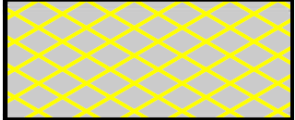
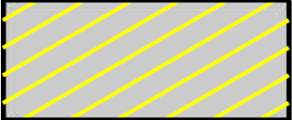
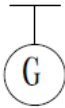
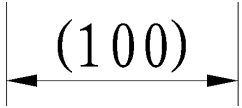
		
Buff point for both sides	Buff point for one side	Penalty zone for both sides
		
Penalty zone for one side	The plane on which the battlefield is located is its lowest plane	Dimensions are for reference only

Release Notes

Date	Version	Changes
October 15, 2020	V1.0	First release

Table of Contents

Intellectual Property Statement	2
Reading Tips.....	2
Legend.....	2
Legend for Battlefield Drawings.....	2
Release Notes	3
1. Introduction	10
1.1 Main Changes to New Competition Season	10
1.2 Overview of Competition Process	10
1.3 Robot and Operator	11
1.3.1 Robot Lineup	11
1.3.2 Basic Robot Information.....	11
1.3.3 Operator Lineup.....	17
1.4 Tactical Coach	18
2. Competition Area	19
2.1 Overview.....	19
2.2 Base Zone.....	22
2.2.1 Starting Zone.....	23
2.2.2 Base	23
2.2.3 Dart Launching Station.....	26
2.2.4 Landing Pad	28
2.2.5 Radar Base	28
2.2.6 Supplier Zone	29
2.2.7 Exchange Zone	31
2.2.8 Sentry Rail	32
2.3 Elevated Ground	33
2.3.1 R3 Trapezoidal Elevated Ground	33
2.3.2 R2 Ring-Shaped Elevated Ground	34
2.3.3 R4 Trapezoidal Elevated Ground	36
2.3.4 Power Rune Activation Point	37
2.3.5 Road Zone	38
2.4 Open Zone.....	40
2.4.1 Resource Island	40
2.4.2 Outpost.....	43
2.4.3 Bumpy Roads.....	45
2.5 Flight Zone	47
2.5.1 Aerial Safety Rope.....	47
2.6 Miscellaneous	47
2.6.1 Obstacle Block	47

2.6.2	Projectiles	48
2.6.3	Minerals.....	48
2.6.4	Engineer Rescue Card	50
2.6.5	Localization Points.....	50
2.6.6	Operator Room.....	51
3.	Competition Mechanism	52
3.1	Robot Status and Buff Types	52
3.2	HP Deduction Mechanism	53
3.2.1	Initial Firing Speed Exceeds the Limit.....	53
3.2.2	Barrel Overheating and Cooling	54
3.2.3	Exceeding Chassis Power Consumption Limit	55
3.2.4	Attack Damage.....	58
3.2.5	Referee System Going Offline.....	60
3.2.6	Irregular Offline Status	60
3.3	Economic System.....	61
3.3.1	17mm Projectile Redemption Mechanism.....	62
3.3.2	42mm Projectile Allowance Redemption Mechanism	62
3.3.3	Air Support Redemption Mechanism	63
3.4	Battlefield-Related Mechanism	63
3.4.1	Base and Outpost HP.....	63
3.4.2	Relevant Mechanisms on Minerals.....	63
3.4.3	Power Rune Mechanism	64
3.5	Relationship between a Sentry Robot, Outpost and Base.....	67
3.6	Virtual Shield Mechanism	67
3.7	Battlefield Buff Mechanism.....	68
3.7.1	Base Buff Points Mechanism.....	68
3.7.2	Elevated Ground Buff Mechanism	69
3.7.3	Launch Ramp Buff Mechanism	69
3.7.4	Outpost Buff Mechanism	69
3.7.5	Power Rune Buff Mechanism.....	70
3.7.6	Restoration Zone Mechanism	70
3.7.7	Hero Robot Sniper Point Mechanism	70
3.8	Mobile 17mm Launching Mechanism.....	70
3.9	Level-Up Mechanism.....	71
3.9.1	Experience System.....	71
3.9.2	Performance System.....	72
3.10	HP Recovery and Revival Mechanism	75
3.10.1	HP Recovery Mechanism.....	76
3.10.2	Revival Mechanism.....	76
3.11	Mechanism Related to Sentry	77

3.11.1	HP Gain Mechanism	77
3.11.2	Projectile Launching	77
3.12	Aerial Robot-Related Mechanisms	77
3.12.1	Attack Deductions.....	77
3.13	Dart Launching Mechanism.....	77
3.13.1	Detection Window Period	78
3.13.2	Invalid Attacks.....	78
3.14	Logic of Mechanism Overlap.....	78
3.15	Winning Criteria	79
3.15.1	Group Stage	79
3.15.2	Knockout Stage	81
4.	Competition Process	82
4.1	Pre-Match Inspection	83
4.2	Staging Area	84
4.3	Three-Minute Setup Period.....	84
4.3.1	Official Technical Timeout.....	85
4.3.2	Team Technical Timeout.....	86
4.4	Referee System Initialization Period.....	87
4.5	Seven-Minute Round	87
4.6	End of Competition	87
4.7	Match Results Confirmation	88
5.	Violations and Penalties.....	89
5.1	Penalty System.....	89
5.1.1	Forms of Penalties	89
5.1.2	Violation Scores.....	89
5.1.3	Types of Penalties	90
5.1.4	Others.....	92
5.2	Penalty Rules	92
5.2.1	Staff	92
5.2.2	Robots	96
5.2.3	Interaction.....	99
5.3	Serious Violations	102
6.	Irregularities	104
7.	Appeals	105
7.1	Appeal Process.....	106
7.2	Appeal Materials	107
7.3	Appeal Decision.....	107

Tables Directory

Table 1-1 Robot lineup.....	11
Table 1-2 Performance parameters of robots.....	12
Table 1-3 Common mechanisms of robots.....	14
Table 1-4 Buff point mechanisms for robots.....	14
Table 1-5 Key information sources for Hero Robots.....	15
Table 1-6 Key information sources for Engineer Robots.....	15
Table 1-7 Key information sources for Standard Robots.....	16
Table 1-8 Key information sources for Aerial Robots.....	16
Table 1-9 Key information sources for Sentry Robots.....	16
Table 1-10 Key information sources for Dart Systems.....	17
Table 1-11 Key information sources for Radars.....	17
Table 1-12 Operator Lineup.....	18
Table 2-1 Projectile Parameters and Scenarios of Use.....	48
Table 2-2 Coordinates of localization points.....	51
Table 3-1 Robot Status.....	52
Table 3-2 Robot buffs.....	53
Table 3-3 Penalty Mechanism for Exceeding Initial Firing Speed Limit.....	53
Table 3-4 Penalty Mechanism for Exceeding Chassis Power Consumption Limit.....	56
Table 3-5 An armor module's detection speed for different projectile types.....	59
Table 3-6 HP Deduction Mechanism for Attack Damage.....	59
Table 3-7 Consequences of irregular offline status.....	61
Table 3-8 Item redemption rules.....	62
Table 3-9 Levels and Experience Points for Standard, Hero, Sentry and Engineer Robots and Outpost.....	71
Table 3-10 Types of chassis and Launching Mechanisms.....	72
Table 3-11 Attributes of Automatic Standard Robots.....	72
Table 3-12 Attributes of Standard Robot Chassis.....	73
Table 3-13 Attributes of Hero Robot Chassis.....	74
Table 3-14 Attributes of 17mm Launching Mechanisms.....	74
Table 3-15 Attributes of 42mm Launching Mechanisms.....	75
Table 3-16 The length of revival processes for different robots on their first defeat.....	76
Table 3-17 Points for Group Stage.....	79
Table 4-1 Descriptions of Technical Faults.....	85
Table 4-2 Team Technical Timeout Arrangement.....	87
Table 5-1 Forms of Penalties.....	89
Table 5-2 Types of penalties.....	90
Table 5-3 Penalties for Collision.....	99
Table 5-4 Categories of Serious Violations.....	102

Figures Directory

Figure 2-1 Top-view rendering of the Battlefield.....	19
Figure 2-2 Side-view rendering of the Battlefield.....	20
Figure 2-3 Axonometric rendering of the Battlefield.....	20
Figure 2-4 Battlefield modules.....	21
Figure 2-5 Localization dimensions for battlefield modules.....	22
Figure 2-6 Base Zone.....	22
Figure 2-7 Robot Starting Zone.....	23
Figure 2-8 Closed state of Base Protective Armor.....	24
Figure 2-9 Expanded state of Base Protective Armor.....	24
Figure 2-10 Dart Detection Module.....	25
Figure 2-11 Base Foundation.....	25
Figure 2-12 Dart Launching Station.....	26
Figure 2-13 Gliding Platform Slides Out.....	27
Figure 2-14 Dimensions for Gliding Platform.....	27
Figure 2-15 Landing Pad.....	28
Figure 2-16 Radar Base.....	29
Figure 2-17 Supplier Zone.....	29
Figure 2-18 Official Projectile Supplier.....	30
Figure 2-19 Restoration Zone.....	31
Figure 2-20 Supplier Penalty Zone.....	31
Figure 2-21 Exchange Zone.....	32
Figure 2-22 Sentry Rail.....	33
Figure 2-23 R3 Trapezoidal Elevated Ground.....	34
Figure 2-24 R2 Elevated Ground.....	35
Figure 2-25 Ring-Shaped Elevated Ground full-site locations.....	35
Figure 2-26 Small Resource Island.....	36
Figure 2-27 R4 Trapezoidal Elevated Ground.....	37
Figure 2-28 Power Rune Activation Point.....	38
Figure 2-29 Power Rune Activation Point Penalty Zone.....	38
Figure 2-30 Road Zone.....	39
Figure 2-31 Launch Ramp.....	40
Figure 2-32 Axonometric view of Resource Island.....	41
Figure 2-33 Front view of Resource Island.....	41
Figure 2-34 Dimensions of Resource Island.....	42
Figure 2-35 Power Rune.....	43
Figure 2-36 Central logo of the Power Rune.....	43
Figure 2-37 Outpost.....	44
Figure 2-38 Dimensions of Outpost.....	45

Figure 2-39 Illustration of the bumps.....	46
Figure 2-40 Bumpy Roads.....	46
Figure 2-41 Initial position of an obstacle block	47
Figure 2-42 Obstacle block.....	48
Figure 2-43 Small Resource Island Minerals	49
Figure 2-44 Resource Island Minerals	49
Figure 2-45 Engineer Rescue Card	50
Figure 2-46 Localization points	50
Figure 2-47 Illustrations of origin of coordinates and included angle.....	51
Figure 3-1 FPV of Client	54
Figure 3-2 (Above) HP Deduction logic and (Below) cooling logic when Barrel Heat limit is exceeded	55
Figure 3-3 Chassis Power Consumption Detection and HP Deduction Logic of Standard and Hero	57
Figure 3-4 Chassis Power Consumption Detection and Chassis Power-off Logic of Sentry.....	58
Figure 3-5 HP Deduction Mechanism for Important Referee System Modules Going Offline	60
Figure 3-6 Numbering for minerals	64
Figure 3-7 Power Rune When Unavailable.....	65
Figure 3-8 Power Rune When Available.....	66
Figure 3-9 Power Rune when activating.....	66
Figure 3-10 Power Rune When Activated	67
Figure 3-11 Battlefield Buff Point Area.....	68
Figure 4-1 Process of a single match.....	82
Figure 4-2 Process of Pre-Match Inspection	83
Figure 5-1 Base Penalty Zone	101
Figure 7-1 Process of an appeal.....	106

1. Introduction

The RoboMaster 2021 University Championship (RMUC 2021) takes the form of shooting battles between robots, in which two teams attack each other's base by launching projectiles in a duration of 7 minutes. Participating teams are required to design, develop and create multiple robots in compliance with specifications to form a battle team.

1.1 Main Changes to New Competition Season

The RMOC may implement changes to the competition rules in the following phases, but they will not involve any revision to the robot-building specifications.



- During Regional Competition: after the end of the competition for a single division.
- During the Final Tournament: after the end of a competition phase (e.g., Group Stage, top-16 matches, etc.).

The RMUC 2021 has been updated with the following changes:

Robots

- The performance mechanisms of Standard and Hero Robots have been updated.
- The projectile supply mechanism has been replaced with an economic system.
- Engineer Robots are no longer required to procure projectile containers. Their tasks now are to mine for minerals and carry obstacle blocks.
- Two new robot types, the Balancing Standard Robot and Automatic Standard Robot, and their relevant mechanisms have been introduced.
- The Fixed Launching Mechanism of Aerial Robots has been removed. Aerial Robots can now be installed with a Mobile 17mm Launching Mechanism.

Battlefield

- A new feature has been added to the Resource Island.
- Changes have been made to the functions of the Official Projectile Supplier.
- The Exchange Station has been added.
- Obstacle blocks have been introduced.
- Certain areas of the Battlefield now have "Bumpy Roads" and ramps.

1.2 Overview of Competition Process

All robots entering the stage must first pass the Pre-match Inspection to ensure they meet the technical specifications set by the RMOC for the purposes of a fair competition. After completing the Inspection, team members need to go

to the Staging Area with their robots to sign the Staging Area Statement, and wait to enter the Competition Area for the match.

Before the start of each match, all teams must be guided by staff to enter the Competition Area from the Staging Area. Each round consists of a Three-Minute Setup Period and a Seven-Minute Round. Between the two periods, there is a 20-Second Referee System Initialization Period.

By the end of each match, teams must clean up projectiles left in the magazine and Launching Mechanism of each robot, return them to the designated area and leave the Competition Area. For detailed descriptions of the competition process, please refer to "4 - Competition Process".

1.3 Robot and Operator

RoboMaster requires robots to fight together as a team with good coordination and teamwork. Building specifications for robots can be found in the "[RoboMaster 2021 University Series Robot Building Specifications Manual](#)".

1.3.1 Robot Lineup

The robot lineup for the RMUC 2021 is as follows:

Table 1-1 Robot lineup

Type	Numbering	Full Team Size (Units)	Competition Stage
Hero Robot	1	1	Regional Competition and Final Tournament
Engineer Robot	2	1	
Standard Robot	3/4	2	Regional Competition
	3/4/5	3	Final Tournament
Aerial Robot	6	1	Regional Competition and Final Tournament
Sentry Robot	7	1	
Dart System	8	1	
Radar	9	1	

Minimum lineup for the first round of each match: Except for Radar and Dart System, four robots.

1.3.2 Basic Robot Information

The performance parameters of robots for the RMUC 2021 are as follows:

Table 1-2 Performance parameters of robots

Robot Type	Initial Projectile (round)	Maximum Chassis Power Consumption (W)	Initial HP	Maximum HP	Initial Firing Speed Limit (m/s)	Barrel Heat Limit	Barrel Cooling Value per Second	Value of Experience Points	Projectile Launch Speed (round/s)	Initial Position
Hero	A total of 100 rounds of 42mm projectiles	Depending on the current robot level and performance level. Refer to "3.8 Level-Up Mechanism" for details. For details on the buffer energy relating to the Maximum Chassis Power Consumption (W), please refer to "3.2.2 Barrel Overheating and Cooling".							For details please refer to "3.2.2 Barrel Overheating and Cooling".	Starting Zone
Engineer		No limit	500	500	For details please refer to "3.2.2 Barrel Overheating and Cooling".		5	For details please refer to "3.2.2 Barrel Overheating and Cooling".	Starting Zone	
Standard	0	Depending on the current robot level and performance level. Refer to "3.8 Level-Up Mechanism" for details. For details on the buffer energy relating to the Maximum Chassis Power Consumption (W), please refer to "3.2.2 Barrel Overheating and Cooling".							For details please refer to "3.2.2 Barrel Overheating and Cooling".	Starting Zone
Aerial	500	-	-	-	30	-	-	-	No limit	Landing Pad
Sentry	500	30	600	600	30	320	100	7.5	For details please refer to "3.2.2 Barrel Overheating and Cooling".	Sentry Rail

Robot Type	Initial Projectile (round)	Maximum Chassis Power Consumption (W)	Initial HP	Maximum HP	Initial Firing Speed Limit (m/s)	Barrel Heat Limit	Barrel Cooling Value per Second	Value of Experience Points	Projectile Launch Speed (round/s)	Initial Position
Dart System	-	-	-	-	18	-	-	-	-	Dart Launching Station
Radar	-	-	-	-	-	-	-	-	-	Radar Base

- Robot chassis: A mechanism that carries and has been mounted with a robot propulsion system and its accessories.
- Chassis Power Consumption: The power propulsion system that enables a robot to move horizontally, not including the power used for special tasks (e.g., power consumption for functional movements such as moving the upper mechanical structure).
- Initial Firing Speed: The speed detected by the relevant modules of the Referee System after a projectile or dart has completed its acceleration. The initial firing speed of a dart can be measured based on the time interval of the dart passing through the speed detection device installed on the Dart Launching Station.
- Initial projectile quantity: The quantity of projectiles that a Pit Crew Member can load into the magazines of a robot before the start of a round.
- Barrel Heat: A mechanism for limiting the firing of projectiles by robots. For more details, please refer to "3.2.2 Barrel Overheating and Cooling".



An Automatic Standard Robot has 500 rounds in Initial Projectile Quantity (17mm projectiles).

The common mechanisms of the robots are as follows:



- "○" indicates: Available
- "-" indicates: Not Available

Table 1-3 Common mechanisms of robots

	Inter-Robot Communication	Mobile 17mm Launching Mechanism	Chassis Power Consumption Limit	Barrel Heat	Level-Up Mechanism	Performance System	External Controller	Carrying Minerals	Carrying Obstacle Blocks
Standard	○	○	○	○	○	○	○	-	○
Engineer	○	-	-	-	-	-	○	○	○
Hero	○	○	○	○	○	○	○	-	○
Sentry	○	-	○	○	-	-	-	-	-
Aerial	○	○	-	-	-	-	To be used only by the aerial gimbal operator	-	-
Dart System	○	-	-	-	-	-	-	-	-
Radar	○	-	-	-	-	-	-	-	-

Table 1-4 Buff point mechanisms for robots

	Restoration Zone	Base Buff Point	Elevated Ground Buff Point	Power Rune Buff Point	Outpost Buff Point	Launch Ramp Buff Point
Standard	○	○	○	○	○	○
Engineer	○	-	-	-	-	-
Hero	○	○	○	○	○	○
Sentry	-	-	-	-	-	-
Aerial	-	-	-	-	-	-

1.3.2.1 Hero Robot

Hero Robots are the only robots that can launch 42mm projectiles on a Battlefield. They are able to inflict additional damage when attacking from a designated location on the Battlefield. The 42mm projectiles to be launched by a

Hero Robot can be mounted on an Engineer Robot or Hero Robot before the match. Hero Robots need to redeem their projectile allowance through the Economic System in the Supplier Zone. In a round of a match, the maximum projectile allowance for a Hero Robot is 100 rounds of 42mm projectiles. After its projectile allowance has been used up, the 42mm Launching Mechanism of a Hero Robot will be powered off.

Table 1-5 Key information sources for Hero Robots

Content	Source
Hero Robot Sniper Point Mechanism	"3.7.7 Hero Robot Sniper Point Mechanism"
Hero Robot Projectile Supply Mechanism	"3.3.2 42mm Projectile Allowance Redemption Mechanism"

1.3.2.2 Engineer Robot

Engineer Robots are the only robots that can carry minerals and rescue other Ground Robots in the Battlefield. They can also move obstacle blocks to set up barriers against enemy robots. Engineer Robots are allowed to load 42mm projectiles during the Three-Minute Setup Period.

Table 1-6 Key information sources for Engineer Robots

Content	Source
Minerals	"2.6.3 Minerals" "3.4.2 Relevant Mechanisms on Minerals"
Engineer Robot rescue	"3.9 HP Recovery and Revival Mechanism"
Triangular obstacle blocks	"2.6.1 Obstacle Blocks"

1.3.2.3 Standard Robot

Standard Robots can be built in the manually operated four-wheel form, or as any of the following two:

- **Balancing Standard Robot:** The parts of a robot that have borders and are in contact with the ground are its "contact surfaces" (those that are unconnected are its "independent contact surfaces"). If at least one straight line on a surviving Standard Robot intersects with all its contact surfaces, the Standard Robot can be fitted with a balancing chassis. Only Standard Robots with a balancing chassis are allowed additional Barrel Heat Buffs. These Standard Robots are called "Balancing Standard Robots".
- **Automatic Standard Robot:** Automatic Standard Robots are not given any options on their chassis or barrel types, but their performance parameters are superior than other robots. An Automatic Standard Robot does not have an operator. The aerial gimbal operator can send commands to an Automatic Standard Robot through the small map (the specifics to be released later).

Table 1-7 Key information sources for Standard Robots

Content	Source
Attributes of Automatic Standard Robots	"Table 3-11 Attributes of Automatic Standard Robots"
Attributes of Balancing Standard Robots	"Table 3-12 Attributes of Standard Robot Chassis"



A robot can be fitted with a balancing chassis only when it meets the definition of a balancing robot.

1.3.2.4 Aerial Robot

Aerial Robots do not have a Fixed Launching Mechanism. They may be mounted with a 17mm Launching Mechanism, and can redeem air support through the Economic System. Since Aerial Robots do not operate by the concepts of Barrel Heat and HP, the penalties for them exceeding their parameter limits will be explained in a separate section.

Table 1-8 Key information sources for Aerial Robots

Content	Source
Air support	"3.3 Economic System"
Aerial Robot-Related Mechanisms	"3.11 Aerial Robot-Related Mechanisms"

1.3.2.5 Sentry Robot

Sentry Robots are responsible for guarding their team's Base, and are the key to winning the competition. A Sentry Robot remains in the Invincible status as long as its team's Outpost is not destroyed. If a Sentry Robot exceeds its chassis power consumption limit, its HP will not be deducted but the chassis will be powered off.

A Sentry Robot may gain HP by attacking enemy robots.

The projectiles of a Sentry Robot must be loaded before the start of a match. It does not have to clear its projectiles after the end of each round. For one round of a match, a Sentry Robot is given a maximum projectile allowance of 500 rounds of 17mm projectiles. The Launching Mechanism will be powered off automatically once the projectile allowance has been used up.

Table 1-9 Key information sources for Sentry Robots

Content	Source
Relationship between a Sentry Robot, Outpost and Base	"3.5 Relationship between a Sentry Robot, Outpost and Base"
HP Gain Mechanism for Sentry Robots	"3.10.1 HP Gain Mechanism for Sentry Robots"

1.3.2.6 Dart System

The Dart System is made up of the Dart Launcher and darts. The aerial gimbal operator can launch darts through the client interface and the inter-robot communication function of the Referee System. For each round of a match, the Dart Launcher may be loaded with 4 darts. The Dart System is allowed to launch twice, each with a window period of 15s and up to a maximum of 4 darts.

The dart guiding light on the Base and Outpost will turn on once the target can be attacked.

Table 1-10 Key information sources for Dart Systems

Content	Source
Dart Launching Mechanism	"3.12 Dart Launching Mechanism"
The timing when the guiding light will be turned on	"3.5 Relationship between a Sentry Robot, Outpost and Base"

1.3.2.7 Radar

A Radar provides vision and warnings to all robots of the team. The Radar is situated outside the Battlefield. The aerial gimbal operator is able to view the Radar images, while the Radar can also relay information to the team's robots through the inter-robot communication function.

The radar's computing system shall be connected to a 220V utility power supply.

Table 1-11 Key information sources for Radars

Content	Source
Initial position of the Radar	"2.2.5 Radar Base"

1.3.3 Operator Lineup



- An operator must be a regular member of a team in the current season.
- An operator can be substituted after each round.
- A pilot can operate an Aerial Robot in the competition only after passing the Pilot Assessment by the RMOC. For details on the Pilot Assessment, please refer to the [RoboMaster 2021 University Championship Participant Manual](#).

The operator lineup is as follows:

Table 1-12 Operator Lineup

Robot Type	Robot Operated	Full Team Lineup Size
Ground Robot Operator	Hero Robot	1
	Standard Robot	Regional Competition: 2 Final Tournament: 3
	Engineer Robot	1
Aerial Gimbal Operator	Aerial, Dart System, Radar	1
Pilot	Aerial Robot	1



Ground Robots: Hero, Engineer and Standard, collectively.

1.4 Tactical Coach

Each team is allowed to have a tactical coach, who can enter the operator room during the Three-Minute Setup Period to set up tactical arrangements with the operator. The tactical coach must leave the operator room before the end of the Three-Minute Setup Period.

The tactical coach can be any participating member in the team (apart from reserve members).

2. Competition Area

2.1 Overview



- The error margin for the dimensions of all Battlefield Components described in the document is $\pm 5\%$. The unit for the size parameters on the site drawings is mm.
- The Battlefield has a symmetrical layout with a central line. All descriptions and illustrations of Battlefield modules in this text will be based on the Red Team as an example but will apply equally to the Blue Team.
- A buff point is an area where robots can receive buffs of a certain nature. Please refer to "3.7 Battlefield Buff Mechanism" for details on the buff point mechanism for the relevant areas mentioned in this chapter.
- A penalty zone is an area that designated robots are forbidden from entering. Please refer to "5.2.3.2 Interaction between Robots and Battlefield Components" for the penalty zone debuff rules for the relevant areas mentioned in this chapter.

The core competition area of the RMUC is called the "Battlefield". The Battlefield is 28 meters long and 15 meters wide, and consists of the Base Zone, Elevated Ground, Resource Island Zone, Supplier Zone and Flight Zone. On the perimeter of the Battlefield is a black steel Perimeter Wall with a height of 2.4 m from its upper edge to the Battlefield ground surface.

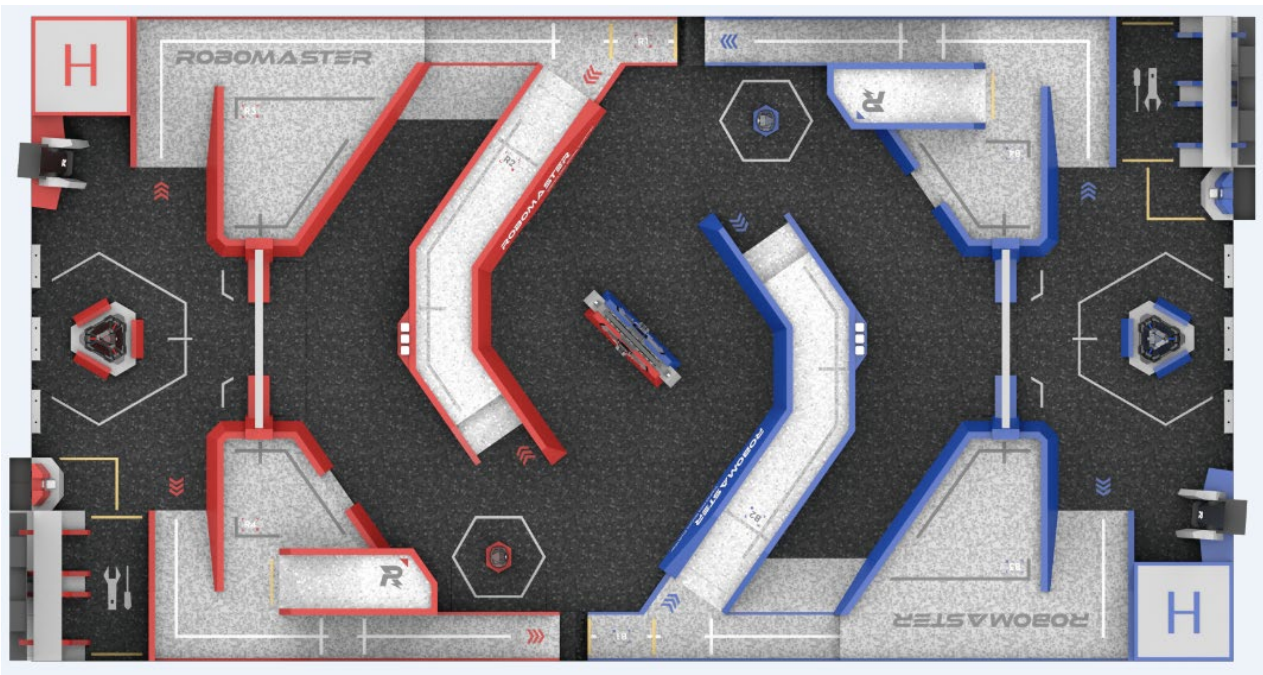

Figure 2-1 Top-view rendering of the Battlefield

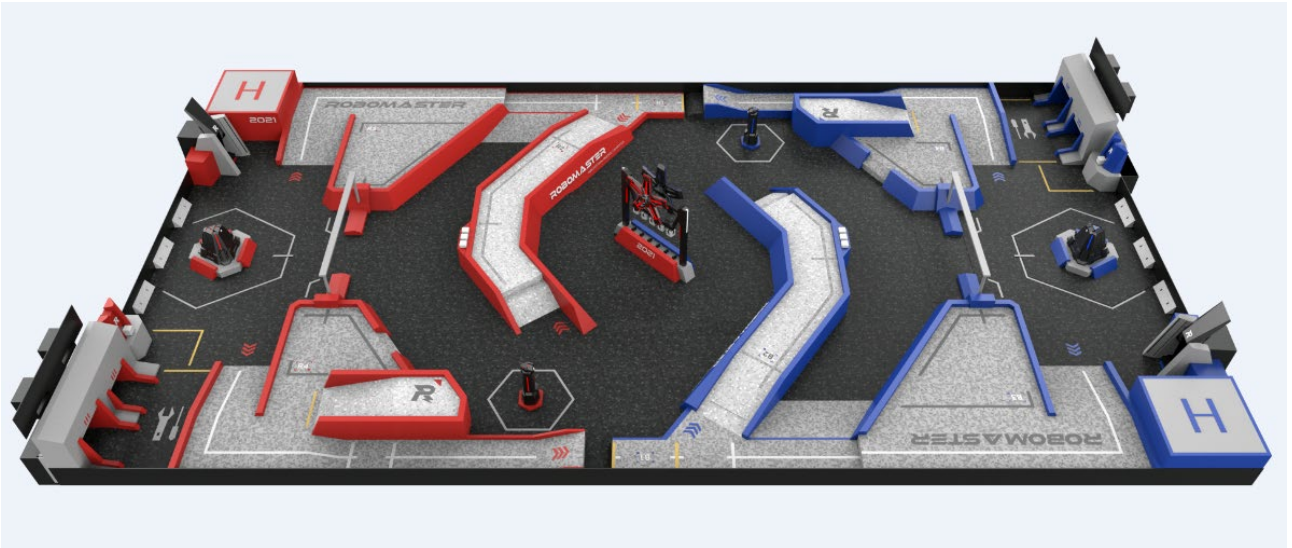
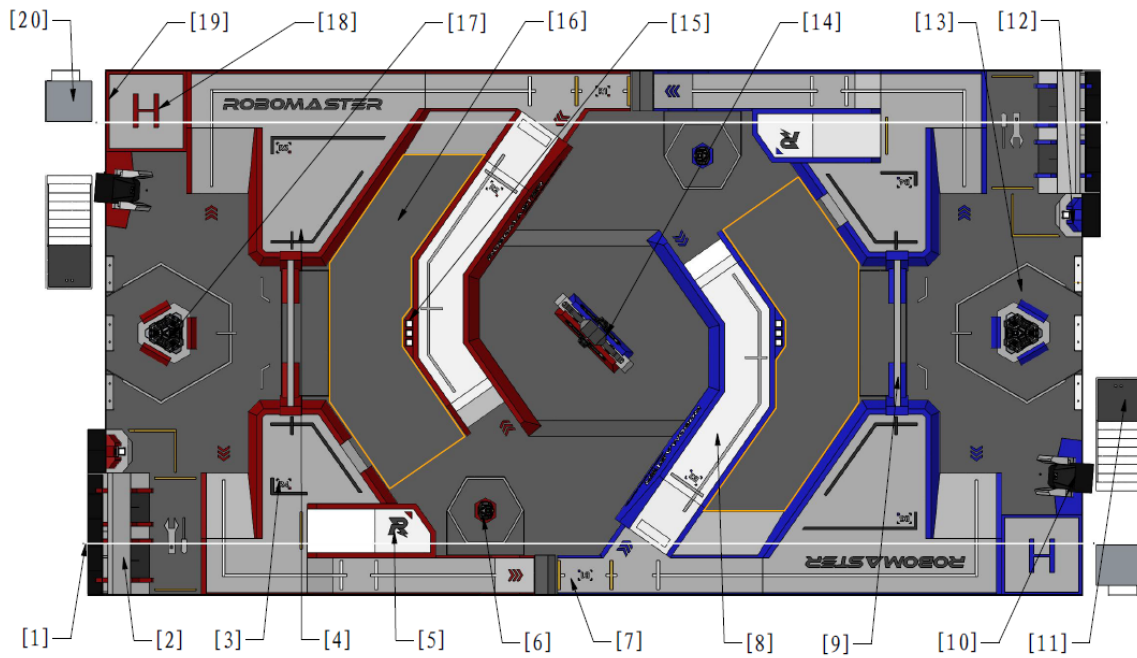

Figure 2-2 Side-view rendering of the Battlefield



Figure 2-3 Axonometric rendering of the Battlefield



- | | | | |
|---------------------------------|-----------------------------|-------------------------------------|------------------------------------|
| [1] Aerial Safety Rope | [2] Supplier Zone | [3] R3 Trapezoidal Elevated Ground | [4] R4 Trapezoidal Elevated Ground |
| [5] Power Rune Activation Point | [6] Outpost | [7] Road Zone | [8] B2 Ring-Shaped Elevated Ground |
| [9] Sentry Rail | [10] Dart Launching Station | [11] Radar Base | [12] Exchange Zone |
| [13] Starting Zone | [14] Resource Island | [15] Small Resource Island | [16] Bumpy Roads |
| [17] Base | [18] Landing Pad | [19] Aerial Robot projectile reload | [20] Pilot Room window |

Figure 2-4 Battlefield modules

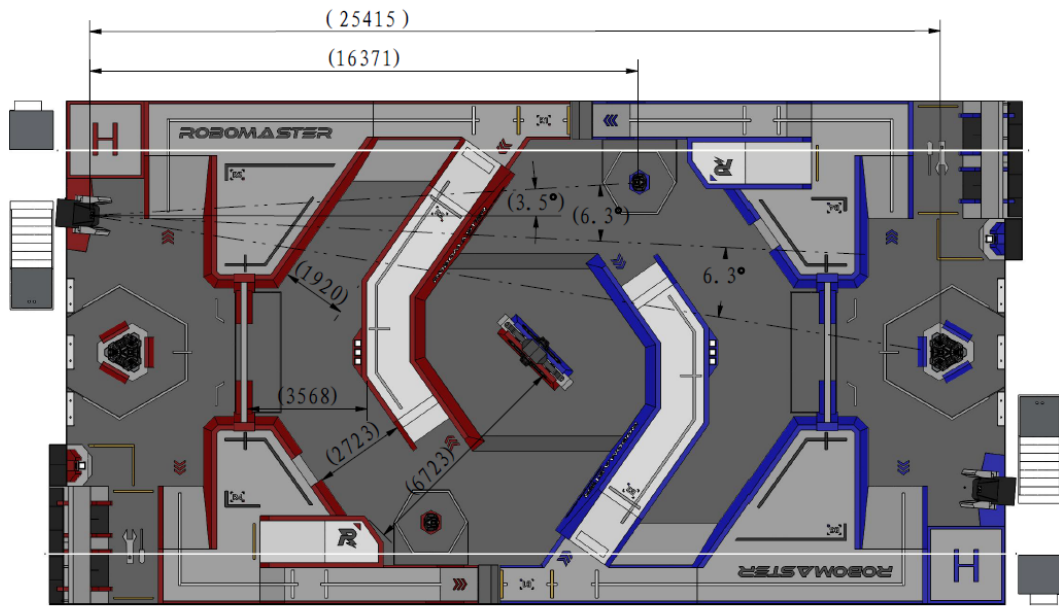
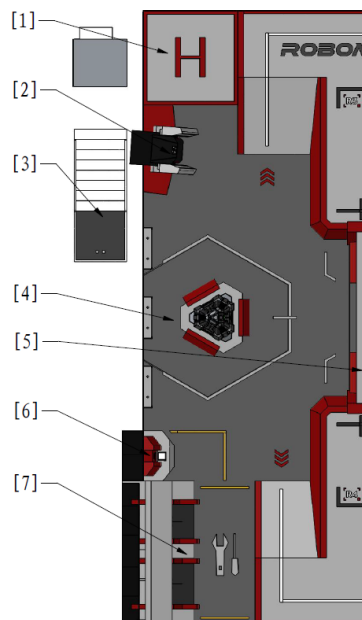

Figure 2-5 Localization dimensions for battlefield modules

2.2 Base Zone

The Base Zone consists of the Starting Zone, Base, Dart Launching Station, Landing Pad, Radar Base, Supplier Zone, Exchange Zone and Sentry Rail. The Starting Zone is the hexagonal area around the Base, while the Base, Dart Launching Station, Landing Pad, Radar Base, Supplier Zone, Exchange Zone and Sentry Rail are each located around the Starting Zone.



- [1] Landing Pad [2] Dart Launching Station [3] Radar Base [4] Starting Zone
- [5] Sentry Rail [6] Exchange Zone [7] Supplier Zone

Figure 2-6 Base Zone

2.2.1 Starting Zone

The Starting Zone is the hexagonal area near the Base, where robots are placed before the start of a match. The plane of the Starting Zone is about 15 mm from the Battlefield ground.

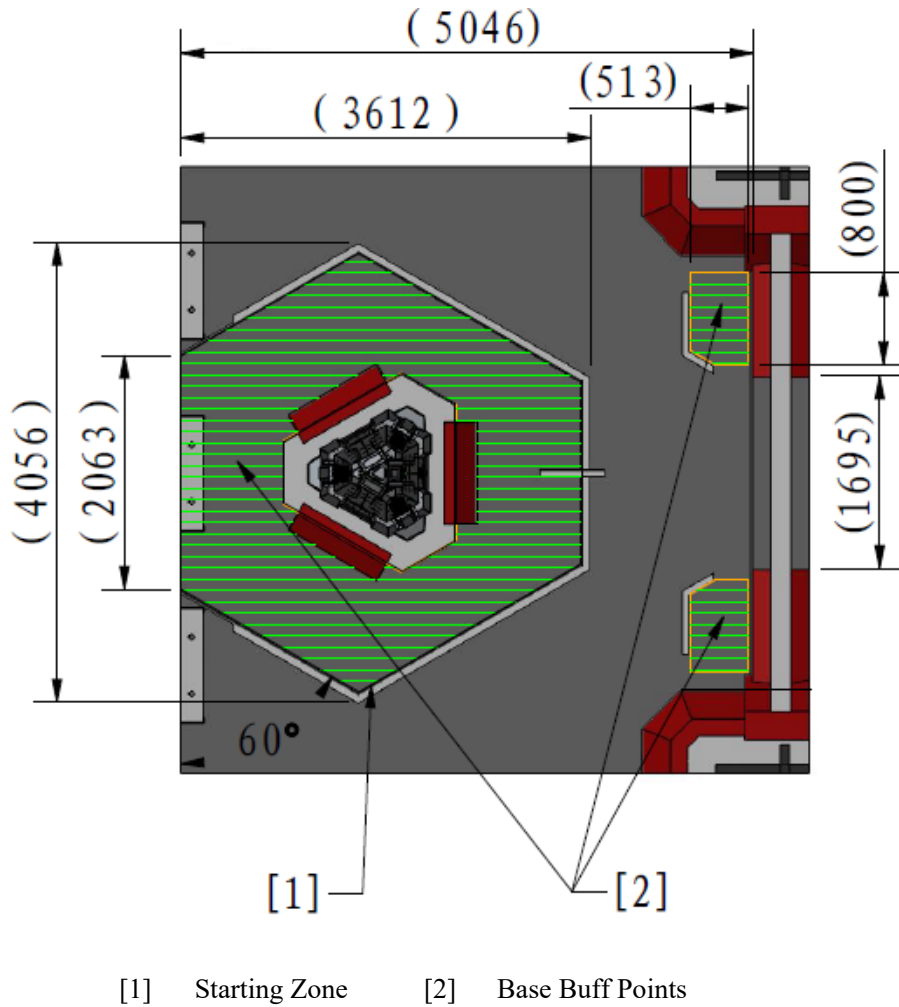

Figure 2-7 Robot Starting Zone

2.2.1.1 Base Buff Points

There are three Base Buff Points, which include the Starting Zone and the area behind the Bunker under the Sentry Rail, as shown in "Figure 2-7 Robot Starting Zone"

2.2.2 Base

A Base is a central component in the competition and the offensive and defensive core of both sides. It is placed on the Base Foundation in the Starting Zones of both teams. A Base consists of the body of the Base, Armor Modules, Dart Detection Module, Base Protective Armor, etc. The Base Protective Armor can either be in a closed or expanded state.

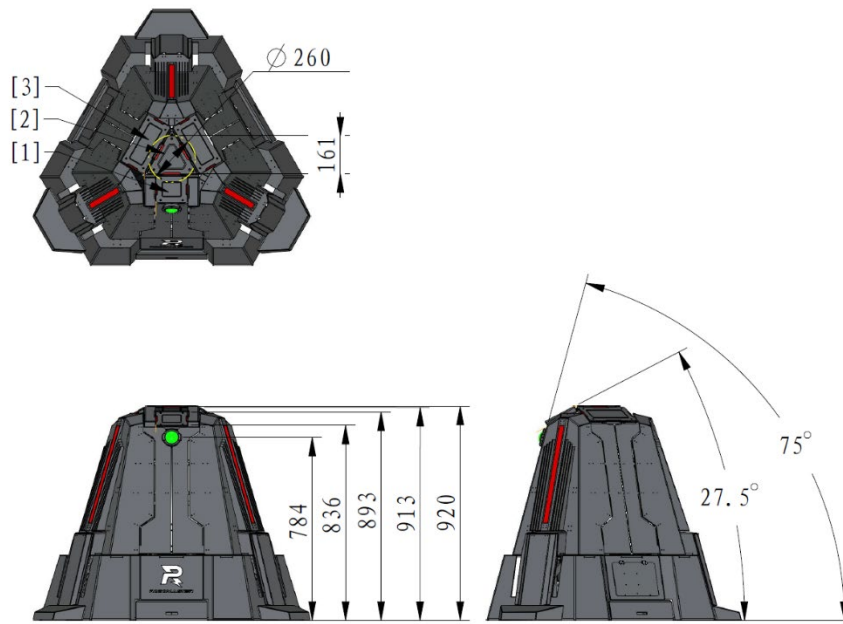

[1] Dart Detection Module [2] Triangular Armor Module [3] Large Armor Module

Figure 2-8 Closed state of Base Protective Armor

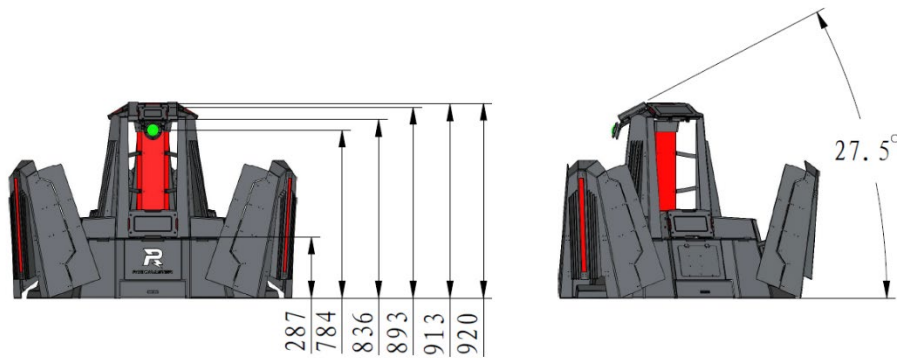
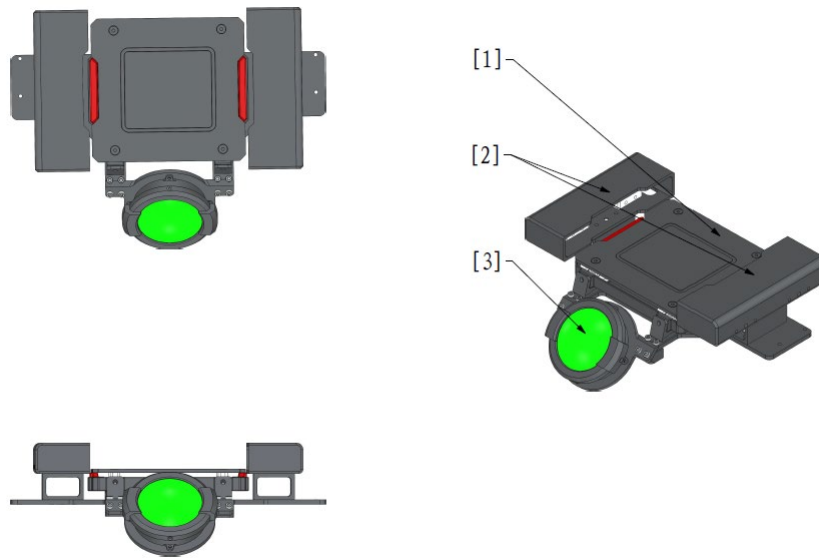

Figure 2-9 Expanded state of Base Protective Armor

The Dart Detection Module is located on the top of the Base and Outpost, consisting of a Small Armor Module, Dart Detection Sensor and dart guiding light.

The Small Armor Module of the Dart Detection Module can detect attacks by darts and 42mm projectiles. The Dart Detection Sensor can detect the infrared light emitted by a dart trigger device. When a Dart Detection Module detects infrared light and an attack simultaneously, the module shall be deemed as having been hit by a dart. When only an attack is detected, the module shall be deemed as having been hit by a 42mm projectile. The dart guiding light has a power of 2W and emits green visible light with a wavelength of 520nm. The diameter of the light-emitting part is 55mm, which is for the purpose of guiding darts in their target attacks.



[1] Small Armor Module [2] Dart Detection Sensor [3] Dart guiding light

Figure 2-10 Dart Detection Module

2.2.2.1 Base Foundation

The Base Foundation is where the Base is placed, and is located in the Starting Zone. The area above the Base Foundation is a Base Penalty Zone.

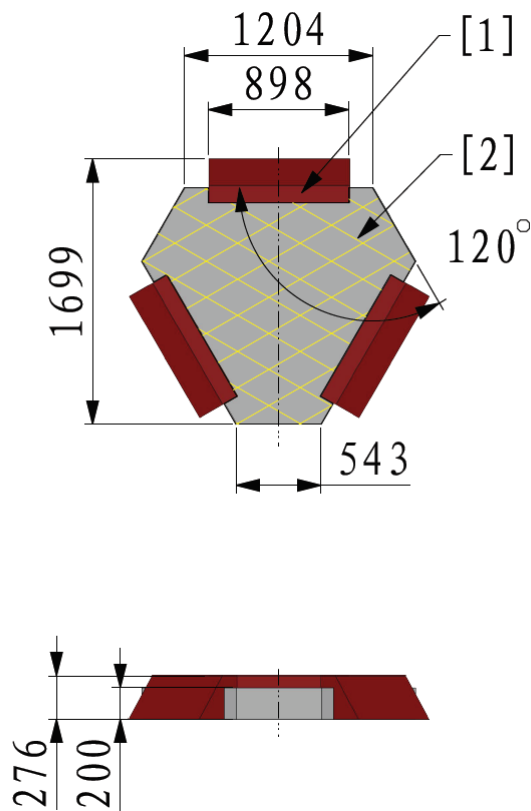

[1] Base Foundation [2] Base Penalty Zone

Figure 2-11 Base Foundation

2.2.3 Dart Launching Station

A Dart Launching Station is where a Dart Launcher is placed.

The Dart Launching Station consists of the body of the station, the gliding platform and the gate. The material of the gliding platform within an area of 600*1,000mm is iron (which is magnetic).

The body of the Dart Launching Station is installed with a speed detection device which can measure the initial firing speed of a dart based on the interval time of it passing through the two parallel flat surfaces. The gliding platform can glide forward and backward for easy placing of a Dart Launcher.

During the Three-Minute Setup Period, the gate of the Dart Launching Station is in the open position, and the Pit Crew Member needs to pull out the gliding platform and place the Dart Launching Station in the square area of the gliding platform. If the Dart Launching Station has not established any regular connection with the server, the "R" indicator on the gate is off, otherwise a white light will flash on the indicator at a frequency of 2 Hz. After confirming the dart launching system is operating normally, the Pit Crew Member needs to push the gliding platform back into the body of the Launching Station until the gliding platform reaches the end. The gliding platform will lock itself automatically after it is in place, and the constant white light of the indicator will turn on. If the gliding platform is not properly in place, the indicator will flash at a frequency of 2 Hz. Before the start of a match, the gate will close automatically.

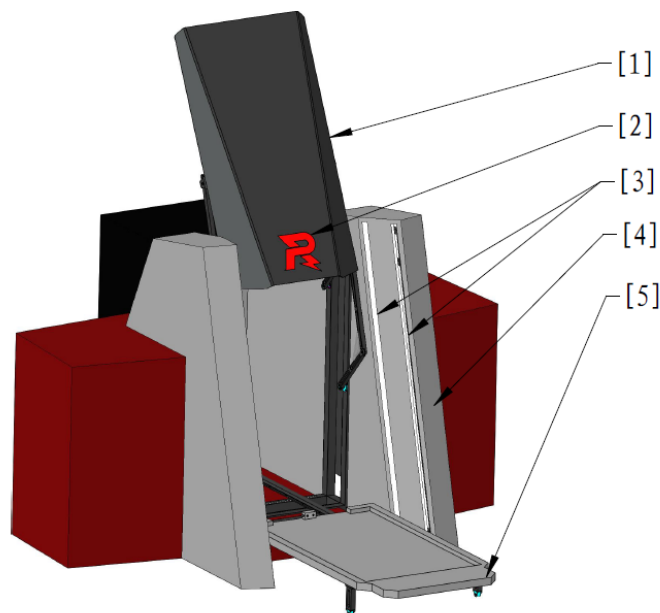

- | | | |
|---|----------------------|----------------------------|
| [1] Gate | [2] Status Light | [3] Speed detection device |
| [4] Main Body of Dart Launching Station | [5] Gliding Platform | |

Figure 2-12 Dart Launching Station

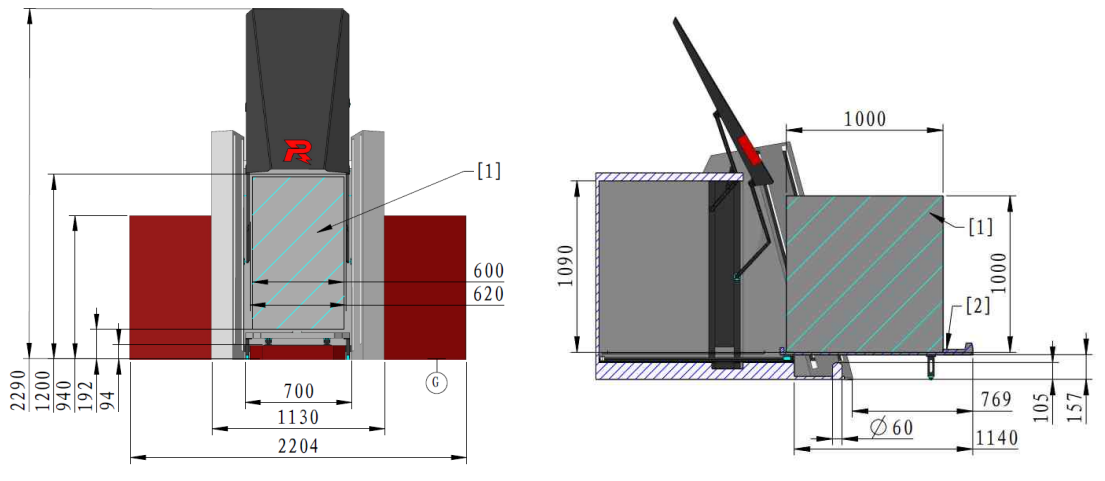

[1] Setting Position of Dart Launcher [2] Gliding Platform

Figure 2-13 Gliding Platform Slides Out

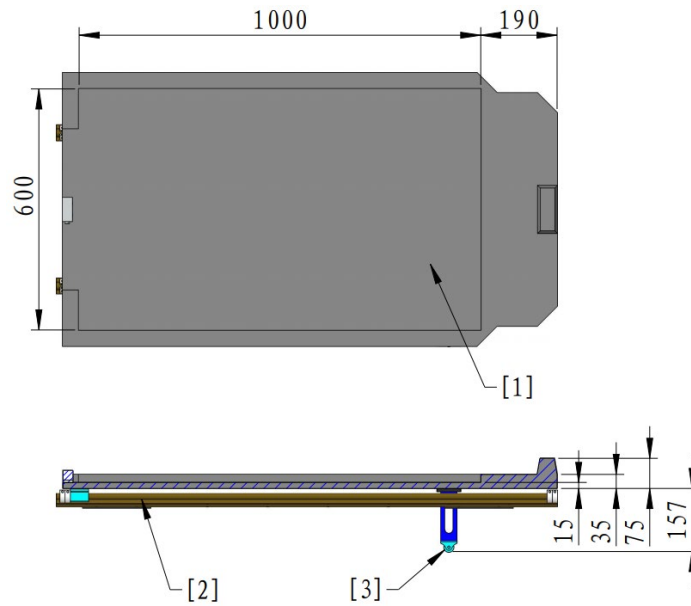

[1] Flat surface for placing Dart Launcher [2] Gliding Platform Rail [3] Supporting wheel

Figure 2-14 Dimensions for Gliding Platform

2.2.4 Landing Pad

The Landing Pad is the initialization zone for Aerial Robots.

Before the start of a match, an Aerial Robot must be placed on a Launching Pad platform and connected to an Aerial Safety Rope according to requirements.

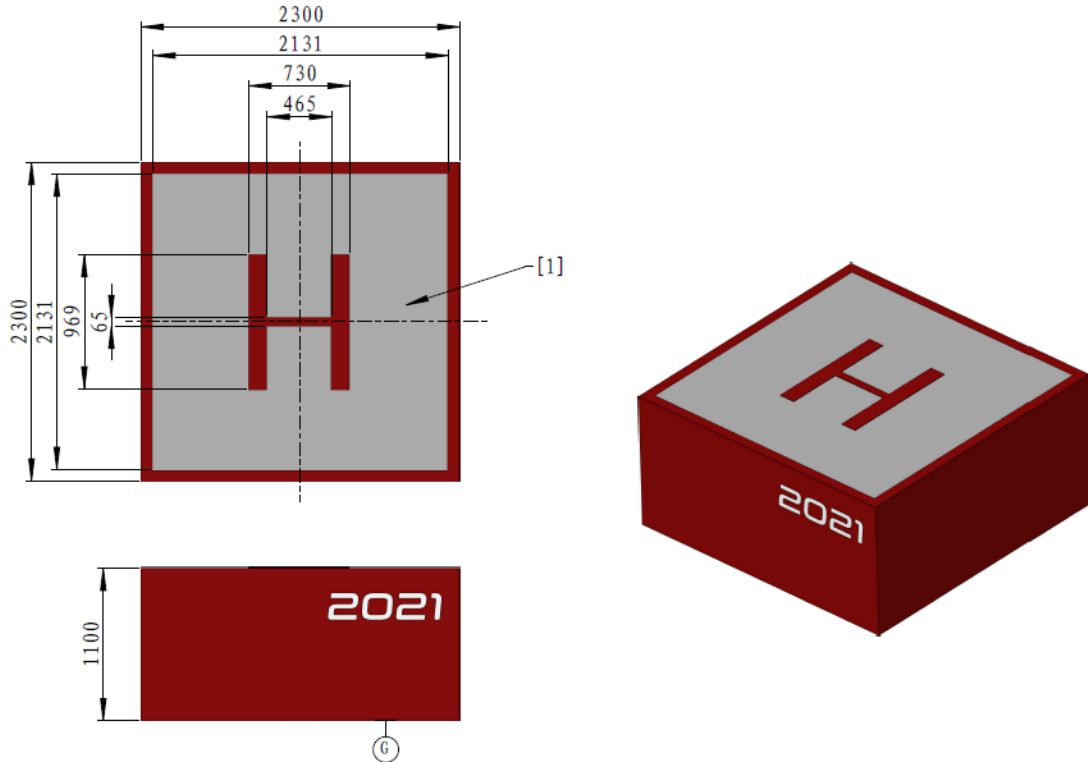

[1] Landing pad platform

Figure 2-15 Landing Pad

2.2.5 Radar Base

A Radar Base is the platform for placing a radar sensor. At its top is a platform with a surface area 1200*1200 mm, made of iron panel material (which is magnetic). The distance from the plane of the platform to the battlefield ground should be 2000 mm, with a non-transparent perimeter wall around that is 1100 mm high. Two cable grooves are on the platform, to be used as required by the conditions of the actual site.

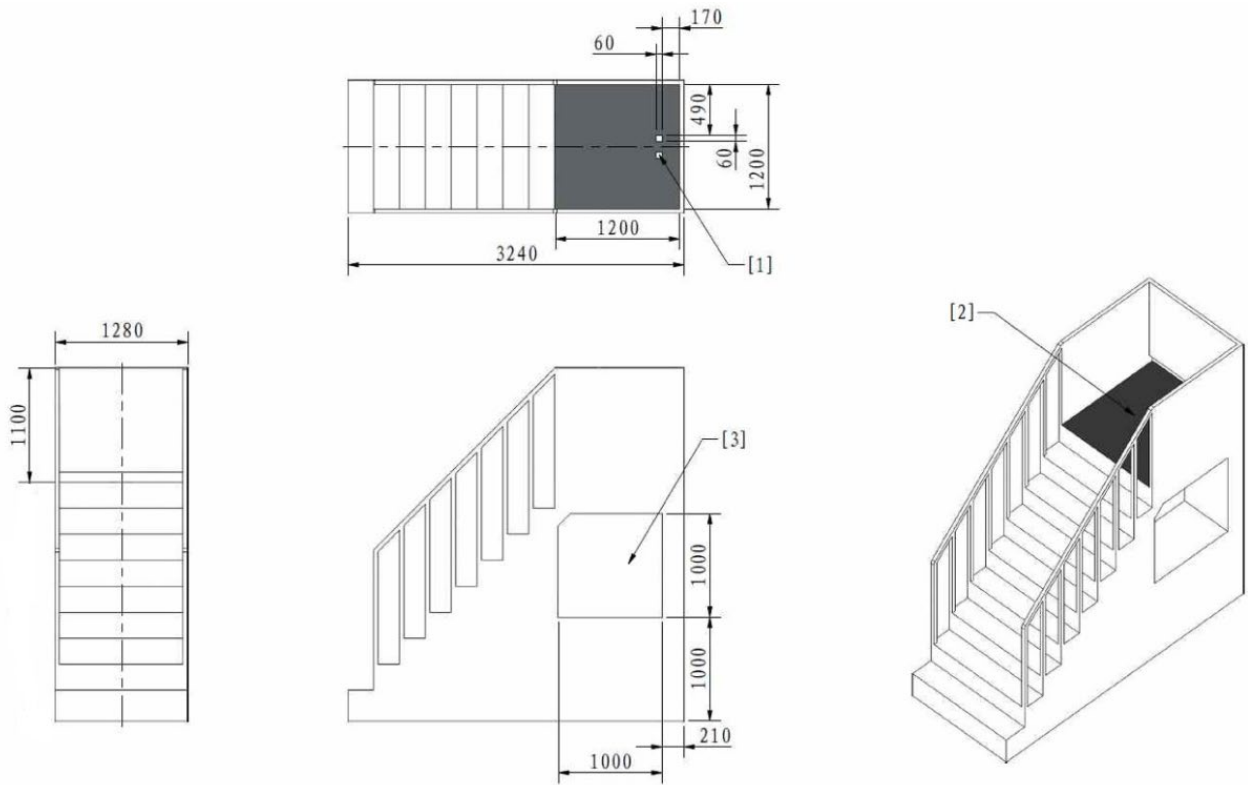

[1] Sensor data cable slot [2] Iron panel material [3] Platform for placing the Radar computing end

Figure 2-16 Radar Base

2.2.6 Supplier Zone



Due to the large size of the Projectile Outlet, teams are advised to enlarge the Projectile Loading Port and pad the internal wall of the Projectile Magazine with buffer materials, to prevent projectiles from falling in the process of loading them into the magazine.

A Supplier Zone is an important area for the reloading of projectiles, revival of defeated robots and recovery of HP.

A Supplier Zone consists of the Restoration Zone and Official Projectile Supplier.

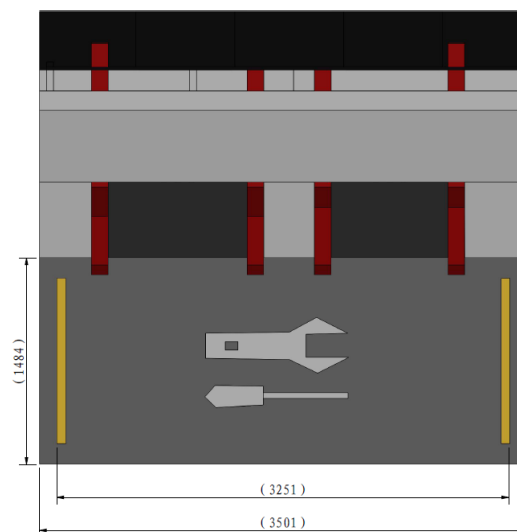

Figure 2-17 Supplier Zone

2.2.6.1 Official Projectile Supplier



Cross laser light: formed by two horizontal laser lights intersected at the center of the Projectile Outlet.

A Projectile Supplier provides 17mm projectiles during matches and consists of a Projectile Outlet, an auxiliary alignment laser sight, a camera and a monitor. The camera of the projectile outlet will capture real-time images of the robot's magazine and display them on the front monitor. The operator can adjust the position of the robot through the laser projected by the cross laser light.

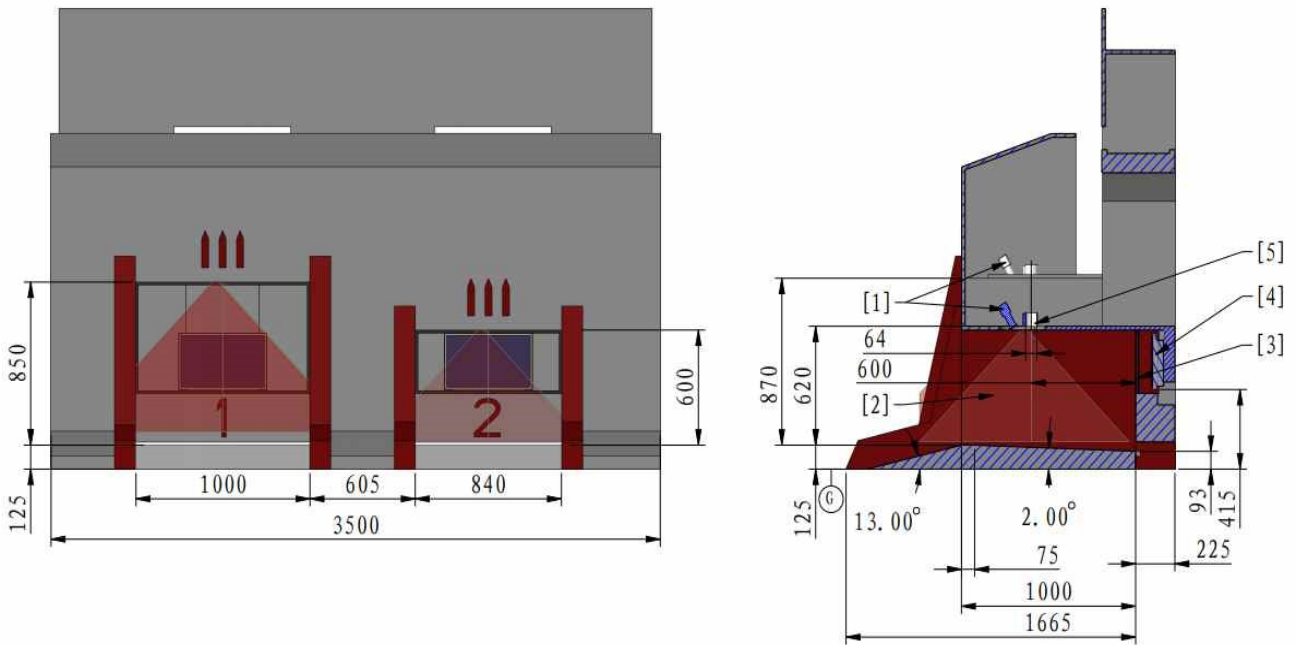

- [1] Camera [2] Laser light path [3] Steel wire mesh
- [4] Monitor [5] Projectile Outlet

Figure 2-18 Official Projectile Supplier

2.2.6.2 Restoration Zone

A Supplier Zone consists of three Restoration Zones. The sizes of the Restoration Zones are 1485*3410 mm, 1000*925 mm and 840*925 mm.

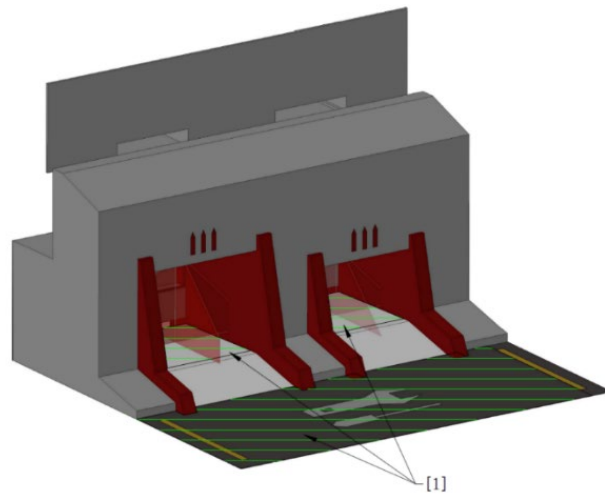

[1] Restoration Zone

Figure 2-19 Restoration Zone

2.2.6.3 Supplier Penalty Zone

The Supplier Penalty Zone is located in parts of the Supplier Zone and Exchange Zone, as shown below:

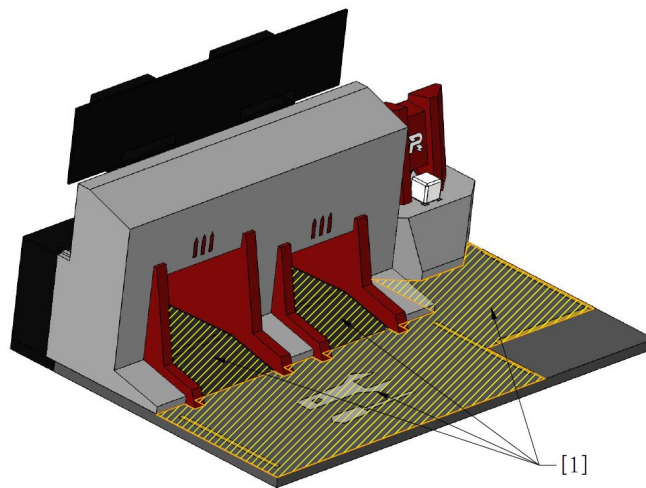

[1] Supplier Penalty Zone

Figure 2-20 Supplier Penalty Zone

2.2.7 Exchange Zone

The Exchange Zone consists of the Exchange Station and the Supplier Penalty Zone in front of the Exchange Station. Robots can redeem minerals at the Exchange Zone for coins.

During the competition, an Engineer Robot may procure minerals from the Resource Island and then place them at the redemption point of the Exchange Station in the correct position (with the bar code facing downwards). When the RFID Interaction Module Card of the Exchange Station detects the RFID Interaction Module Card in an mineral, the indicator light will start to flash, which means the mineral exchange is complete. After completing the exchange, the Engineer Robot needs to push the minerals into the receptacle.

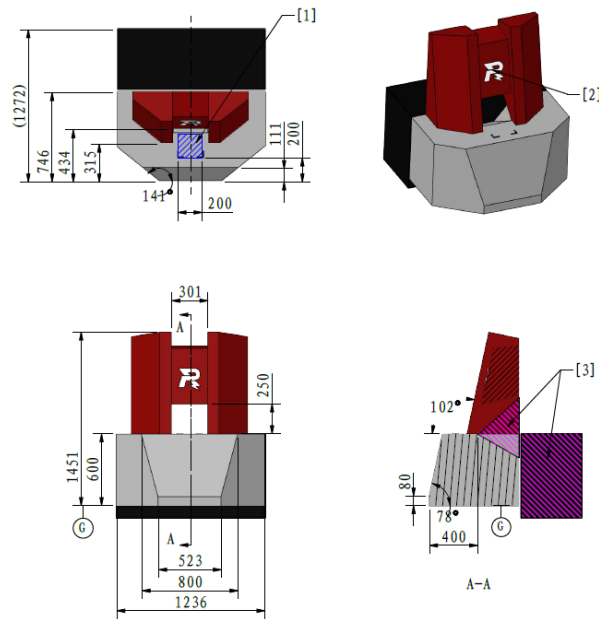

[1] Ore identification zone [2] Light indicator [3] Mineral receptacle

Figure 2-21 Exchange Zone

2.2.8 Sentry Rail



- The parts in the same color represent the same component. Connection and height gaps exist in the assemblage of different components.
- The hexagonal angles of the bolt head are not definite and are for reference only.

The Sentry Rail is the only area where a Sentry Robot can be active. It is located near the Starting Zone, and consists of the body of the Rail and its supporting structure, with a painted surface. The distance between the lower surface of the Sentry Rail and the Battlefield ground should be 1300 mm. However, due to the weight of the Rail, a certain height difference will exist between the middle and the ends of the Sentry Rail. Therefore the actual distance between the lower surface of the Rail and the Battlefield ground should be 1,250-1,300 mm.

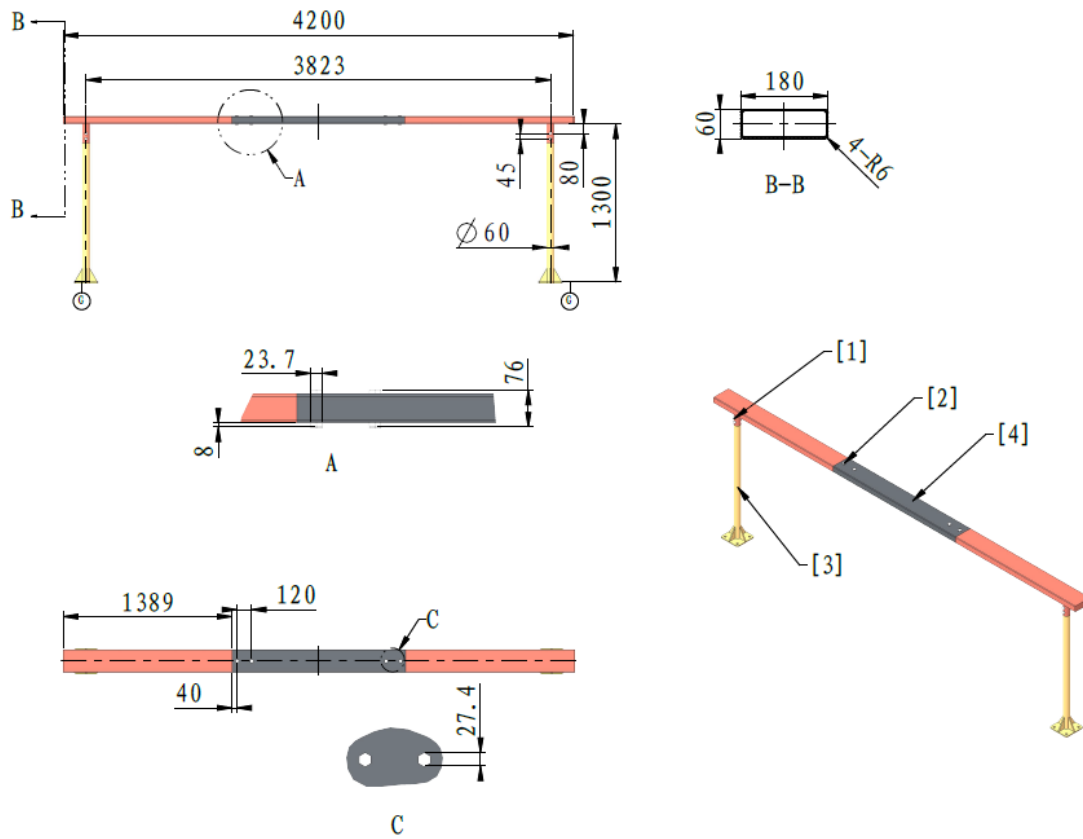

[1] M8 Bolt [2] M16 Bolt [3] Rail Support [4] Main Body of the Rail

Figure 2-22 Sentry Rail

2.3 Elevated Ground

An Elevated Ground is an area higher than the flat ground of the Battlefield. Each side has three Elevated Grounds that divide the Battlefield into different zones and create a three-dimensional space for the Battlefield. The Elevated Grounds include the R3 Trapezoidal, R4 Trapezoidal and R2 Ring-Shaped Elevated Grounds.

2.3.1 R3 Trapezoidal Elevated Ground

The R3 Trapezoidal Elevated Ground is located near the Landing Pad, at a height of 400mm above ground. The height of its perimeter wall is 135mm.

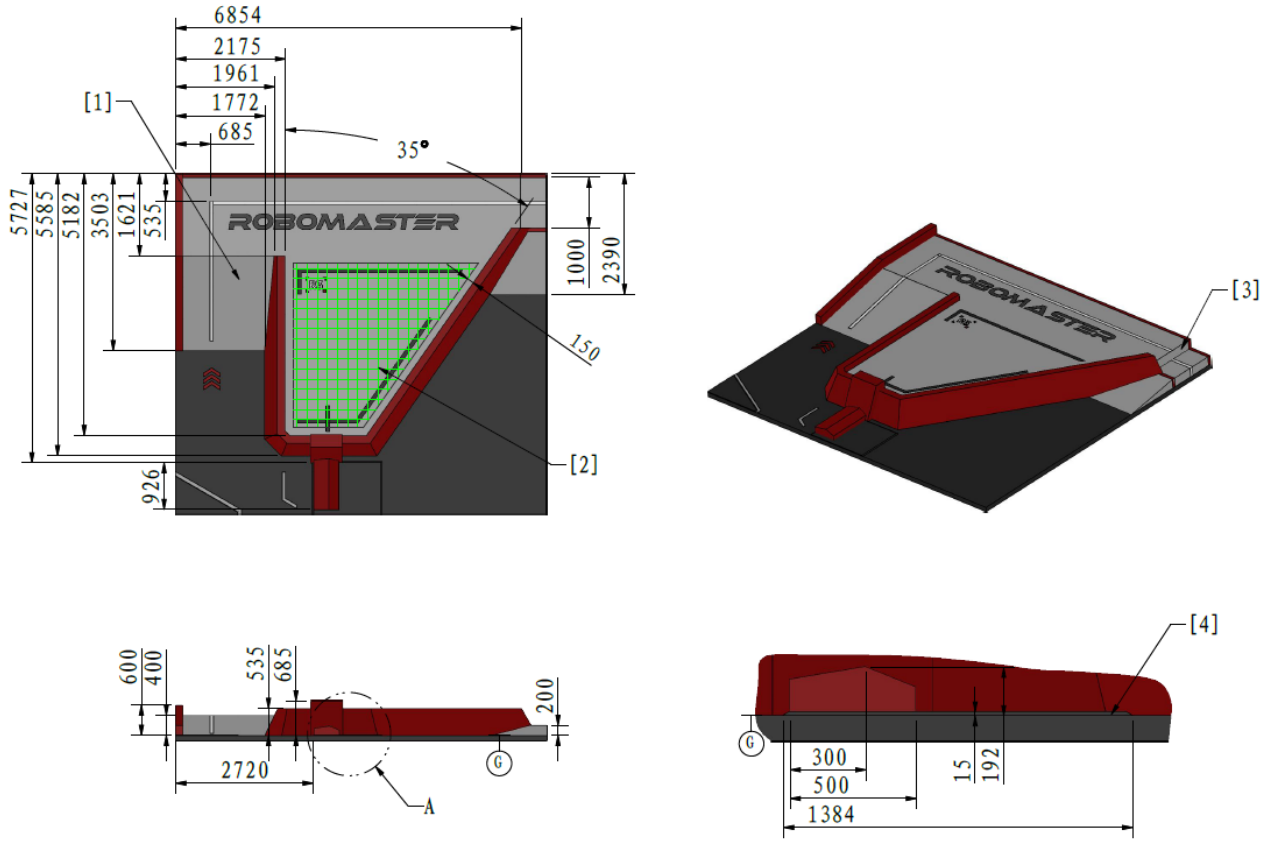

[1] 12° slope [2] Elevated Ground Buff Point [3] 200mm step [4] 15mm base board

Figure 2-23 R3 Trapezoidal Elevated Ground

2.3.1.1 R3 Trapezoidal Elevated Ground Buff Point

The R3 Trapezoidal Elevated Ground has one buff point.

2.3.2 R2 Ring-Shaped Elevated Ground

The R2 Ring-Shaped Elevated Ground is located near the Resource Island Zone, with one end connected to the road through the slope. The Small Resource Island is adjacent to the Ring-Shaped Elevated Ground, and is located outside the protective perimeter wall.

The site localization tag is placed on the vertical surface near the Small Resource Island on the R2 Ring-Shaped Elevated Ground, as shown below. The team's radar can obtain full-site location information through the site localization tag.

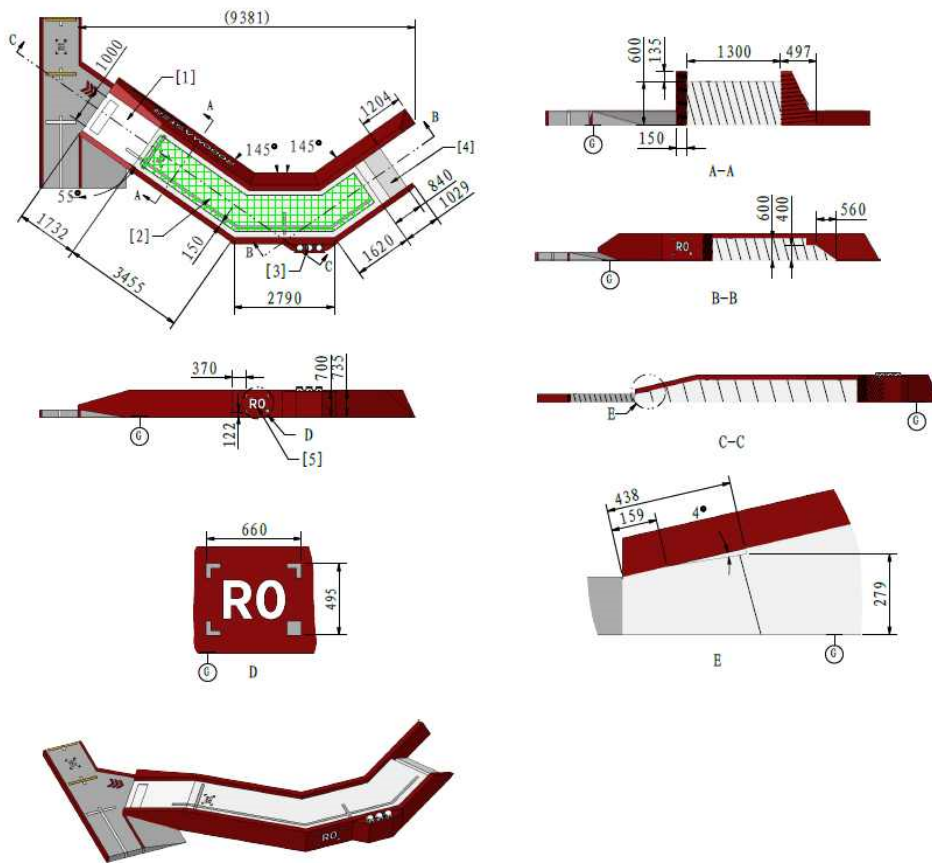

- [1] 13° slope
- [2] Elevated Ground Buff Point
- [3] Small Resource Island
- [4] 15° slope
- [5] Site localization tag

Figure 2-24 R2 Elevated Ground

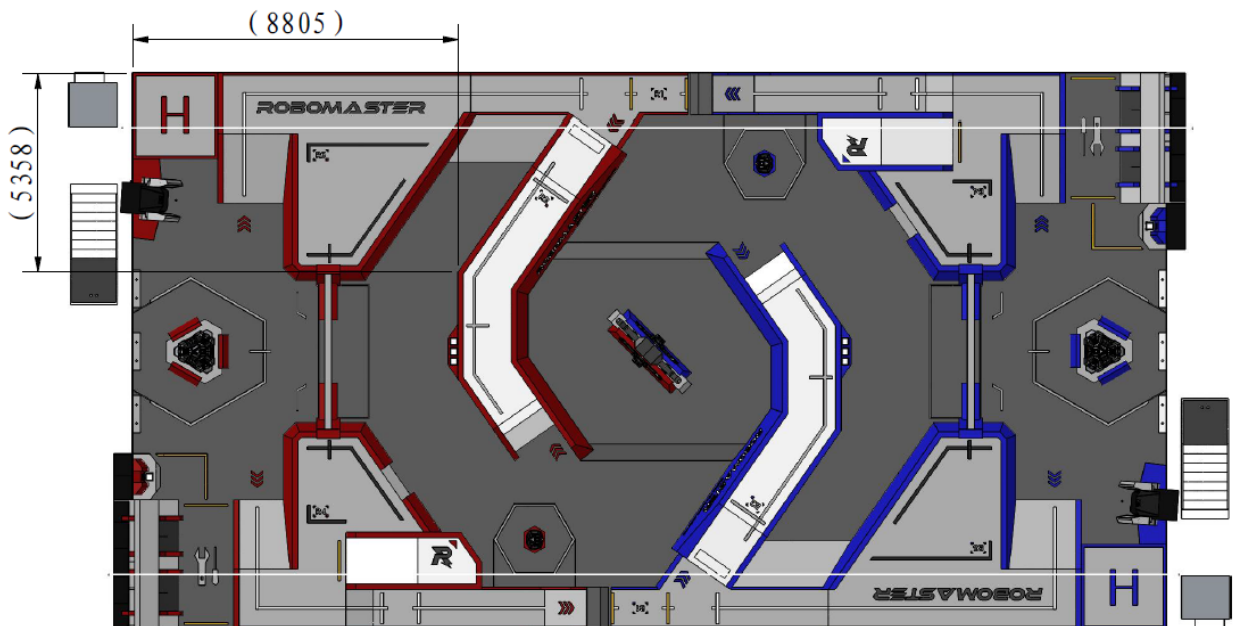

Figure 2-25 Ring-Shaped Elevated Ground full-site locations

2.3.2.1 R2 Elevated Ground Buff Point

The R2 Ring-Shaped Elevated Ground has one buff point.

2.3.2.2 Small Resource Island

The Small Resource Island is adjacent to the Ring-Shaped Elevated Ground and located outside the protective perimeter wall. It has three grooves for minerals.

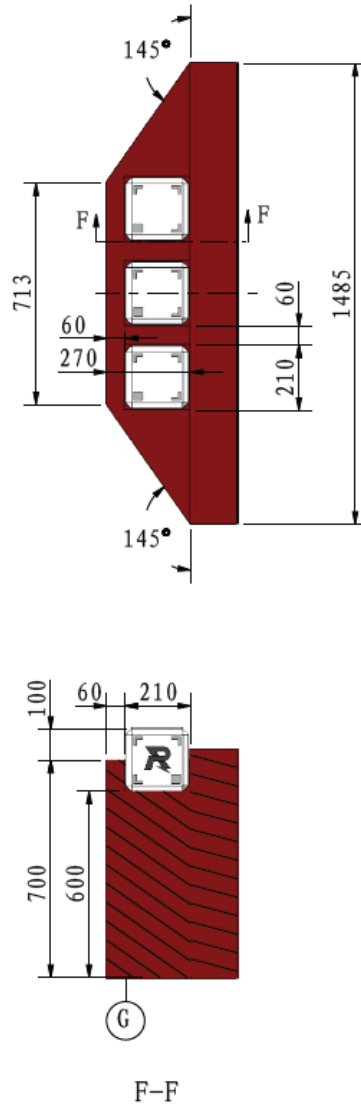

[1] Ring-Shaped Elevated Ground [2] Small Resource Island Minerals

Figure 2-26 Small Resource Island

2.3.3 R4 Trapezoidal Elevated Ground

The R4 Trapezoidal Elevated Ground is located near the Supplier Zone, at a height of 400 mm above ground, and the height of the perimeter walls is 135 mm.

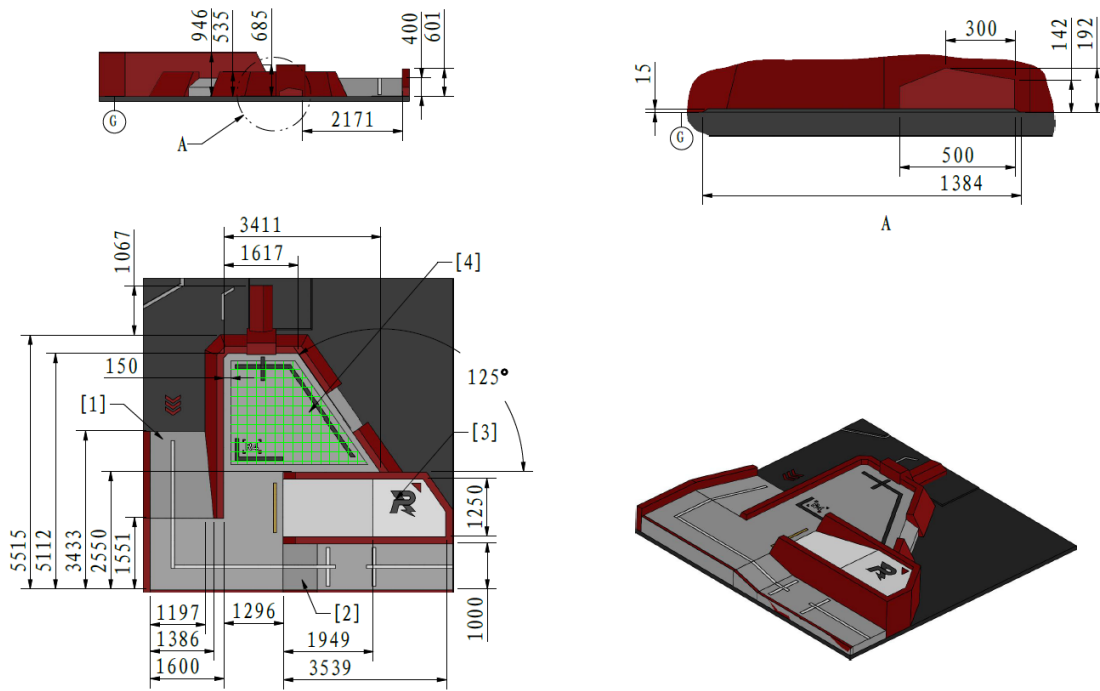

[1] 12° slope

[2] 15° slope

[3] Power Rune Activation Point

[4] R4 Trapezoidal Elevated Ground Buff Point

Figure 2-27 R4 Trapezoidal Elevated Ground

2.3.3.1 R4 Trapezoidal Elevated Ground Buff Point

The R4 Trapezoidal Elevated Ground has one buff point.

2.3.4 Power Rune Activation Point

The Power Rune Activation Point is where a robot hits to activate the Power Rune, and is located on the R4 Trapezoidal Elevated Ground. The activation point is connected to the R4 Trapezoidal Elevated Ground through the slope.

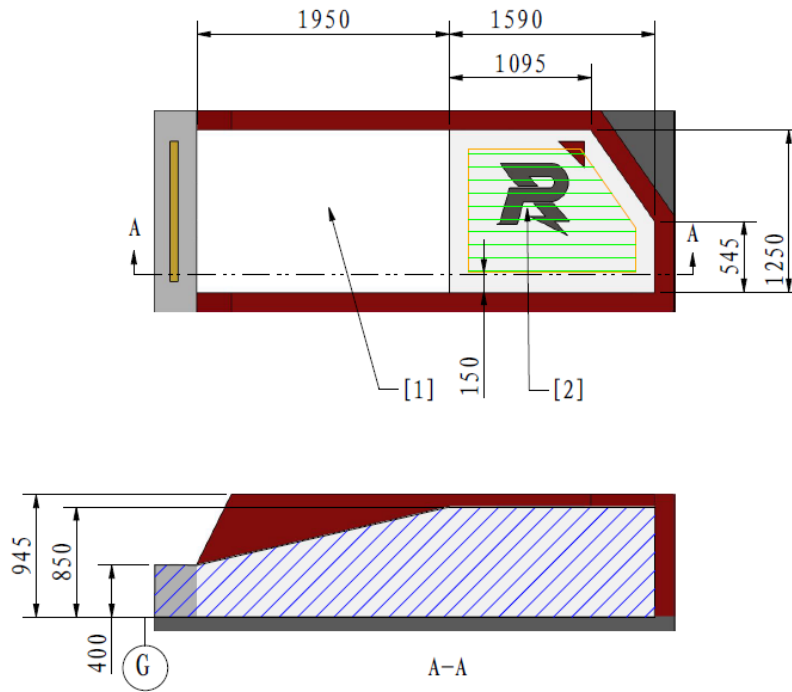

[1] 13° slope [2] Power Rune Activation Point

Figure 2-28 Power Rune Activation Point

2.3.4.1 Power Rune Activation Point Penalty Zone

The Power Rune Activation Point and the slope connecting the Power Rune Activation Point and R4 Trapezoidal Elevated Ground are the Power Rune Activation Point Penalty Zone.

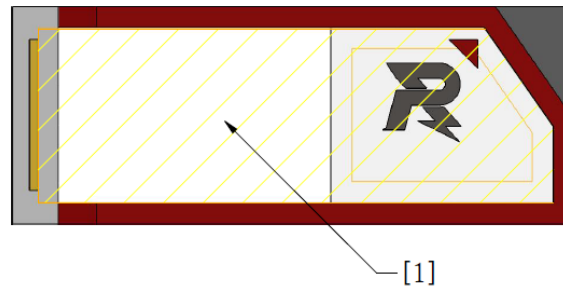

[1] Power Rune Activation Point Penalty Zone

Figure 2-29 Power Rune Activation Point Penalty Zone

2.3.5 Road Zone

The Road Zone connects the R3 Trapezoidal Elevated Ground of one side and the B4 Trapezoidal Elevated Ground of the other side. The Road Zone includes the road and the Launch Ramp.

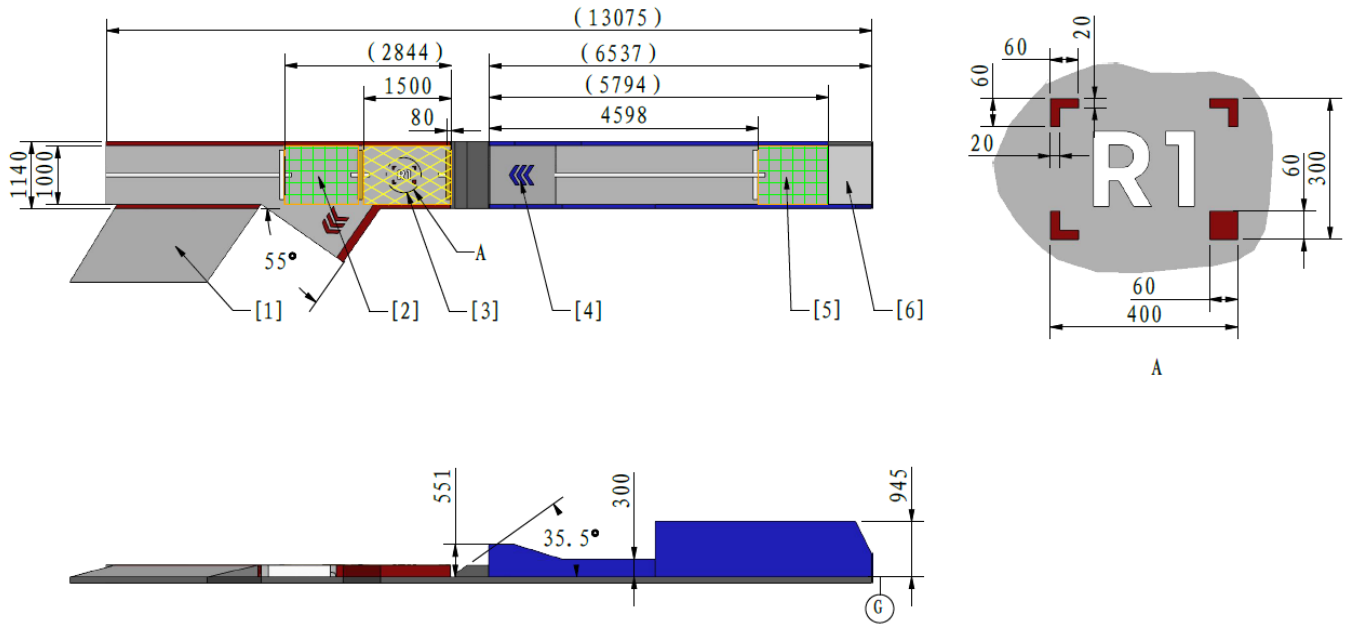

- [1] 9° slope [2] Launch Ramp Buff Detection Point 1 [3] Road Penalty Zone
- [4] 17° slope [5] Launch Ramp Buff Detection Point 2 [6] 15° slope

Figure 2-30 Road Zone

2.3.5.1 Launch Ramp

The Launch Ramp is located on the Road Zone, with which robots can fly over the ravine and reach the territory of the other team quickly. The Road Zone situated 1500 mm from the edge of the ravine is the Buffer Zone. EVA foam rubber with a thickness of 100 mm and hardness of 25 HC should be placed under the road surface.

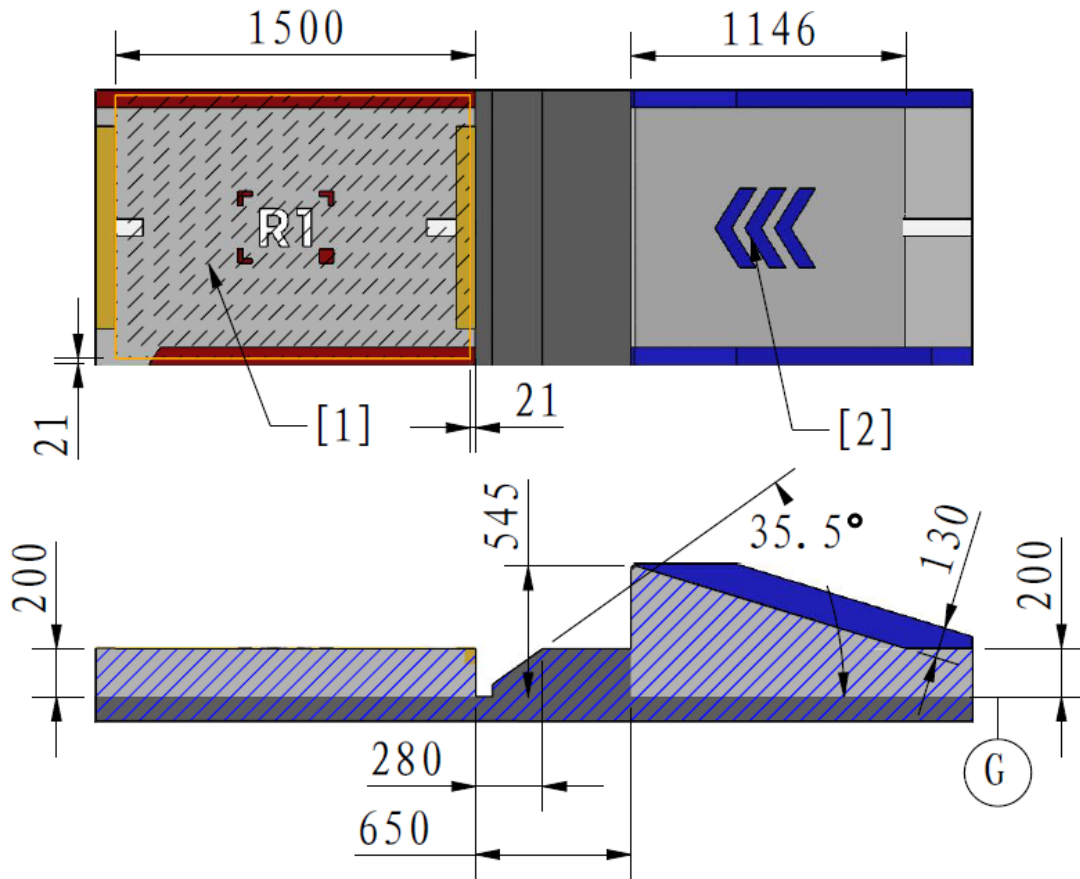

[1] Buffer zone [2] 17° slope

Figure 2-31 Launch Ramp

2.3.5.2 Launch Ramp Buff Detection Point

Each road has two Launch Ramp Buff Detection Points. They are located respectively on the road surfaces in front of and behind the Launch Ramp, as shown in "Figure 2-30 Road Zone"

2.3.5.3 Road Penalty Zone

The Buffer Zone on the road and the ravine are the Road Penalty Zone. Except for using the Launch Ramp, the robots of both sides are forbidden from entering the zone.

2.4 Open Zone

The ground areas outside the Base Zones of both teams are the Open Zone, which consists of the Outpost and Resource Island. Part of the Open Zone are Bumpy Roads.

2.4.1 Resource Island

The Resource Island is situated at the center of the Battlefield and directly below the Power Rune, and has 5 minerals.

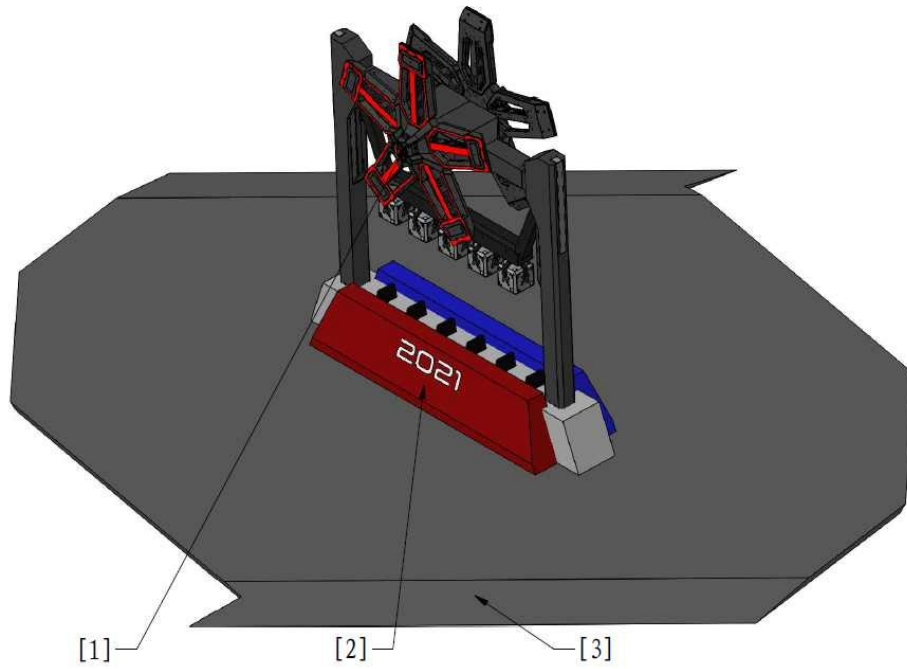

[1] Power Rune [2] Resource Island [3] 12° slope

Figure 2-32 Axonometric view of Resource Island

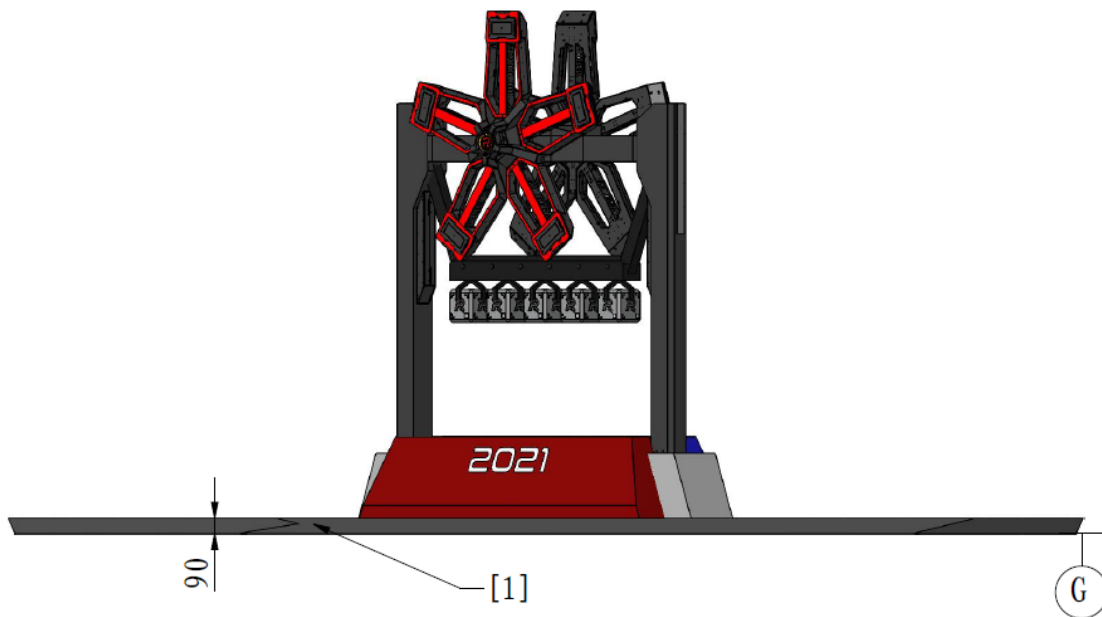

[1] 90mm platform ground

Figure 2-33 Front view of Resource Island

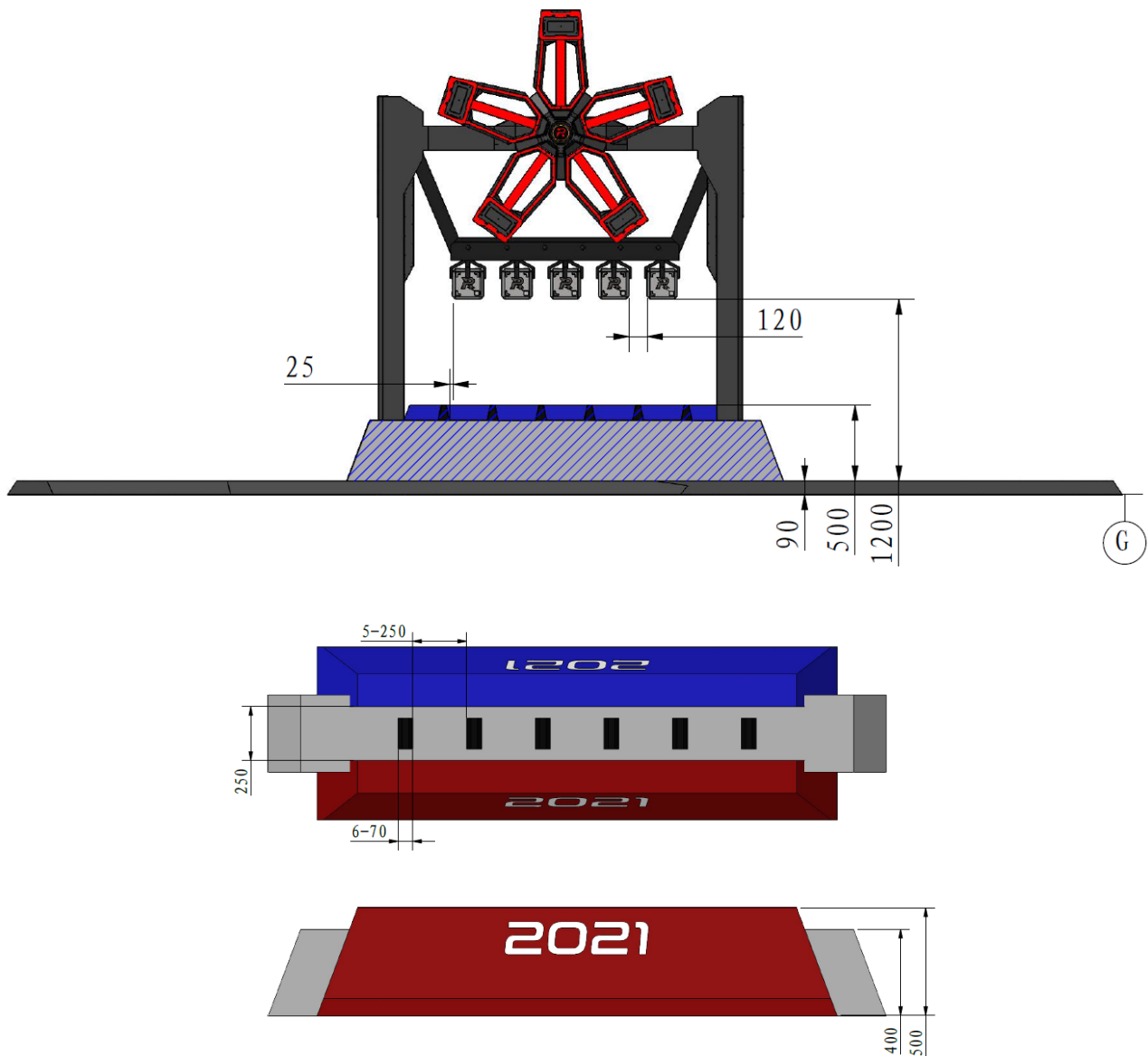

Figure 2-34 Dimensions of Resource Island

2.4.1.1 Power Rune



- The Power Rune will have a slight dip in the middle due to its weight. The dip is around 0~50 mm.
- Due to the viewing angle and transmission gap, a team may see parts of the Power Rune of the other side when observing its own Power Rune.

The Power Rune is located directly above the Resource Island. The Power Rune is powered by the motor and rotates at a regular rhythm. A robot needs to occupy the Power Rune Activation Point to activate the Power Rune. The Power Rune of the red team is located one side and that of the blue team are located on the other. The Power Runes of both teams rotate on the same axis.

A Power Rune has five mounting brackets that are distributed evenly. The end of each mounting bracket is installed with a Large Armor Module. The specific location and dimensions of the Large Armor Module are as follows:

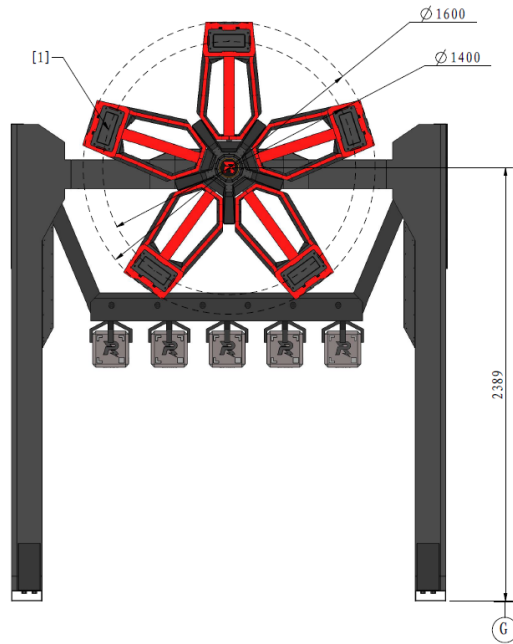

[1] Large Armor Module

Figure 2-35 Power Rune

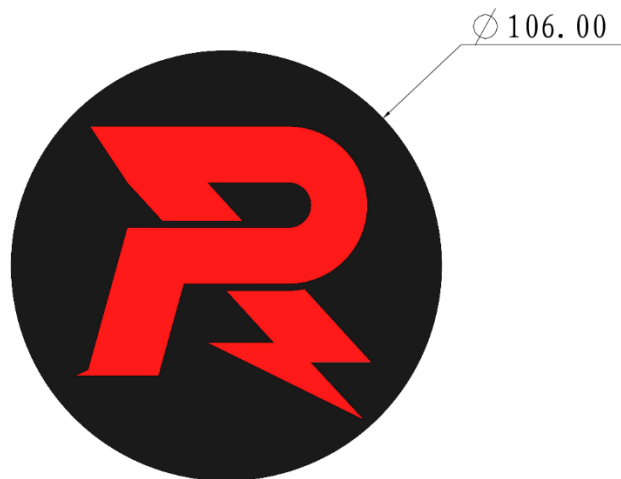
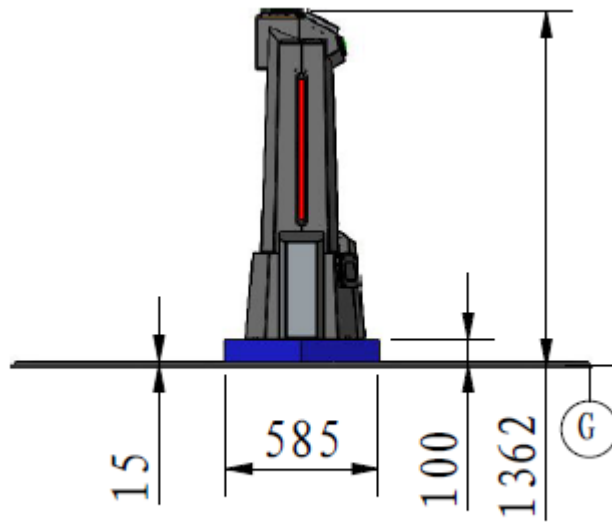
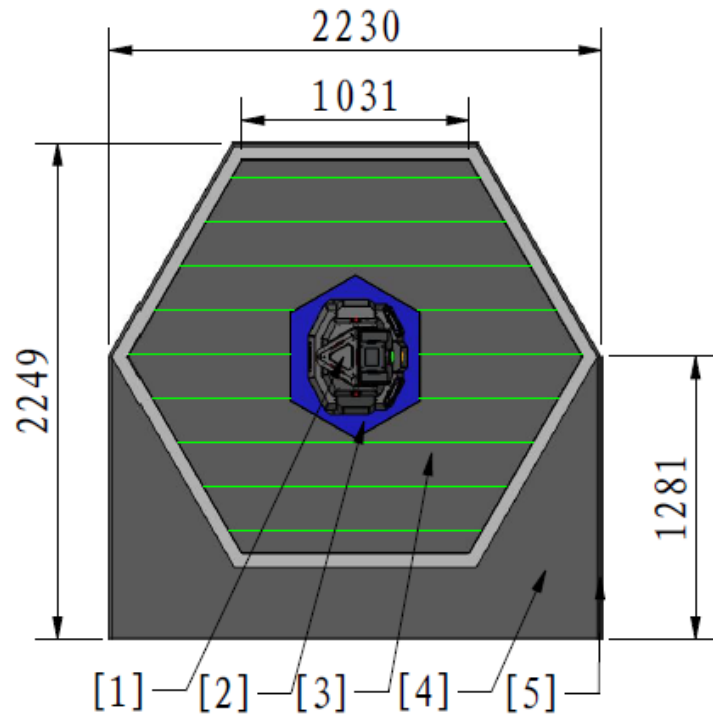

Figure 2-36 Central logo of the Power Rune

2.4.2 Outpost

The Outpost is placed on the Outpost Base, near the Launch Ramp. The Outpost consists of the body of the Outpost, Armor Module, Dart Detection Module and other components. Refer to "Figure 2-10 Dart Detection Module" for a drawing of the Dart Detection Module.



- [1] Outpost [2] Outpost Base [3] Outpost Buff Point
- [4] Outpost base board [5] 45° Slope

Figure 2-37 Outpost

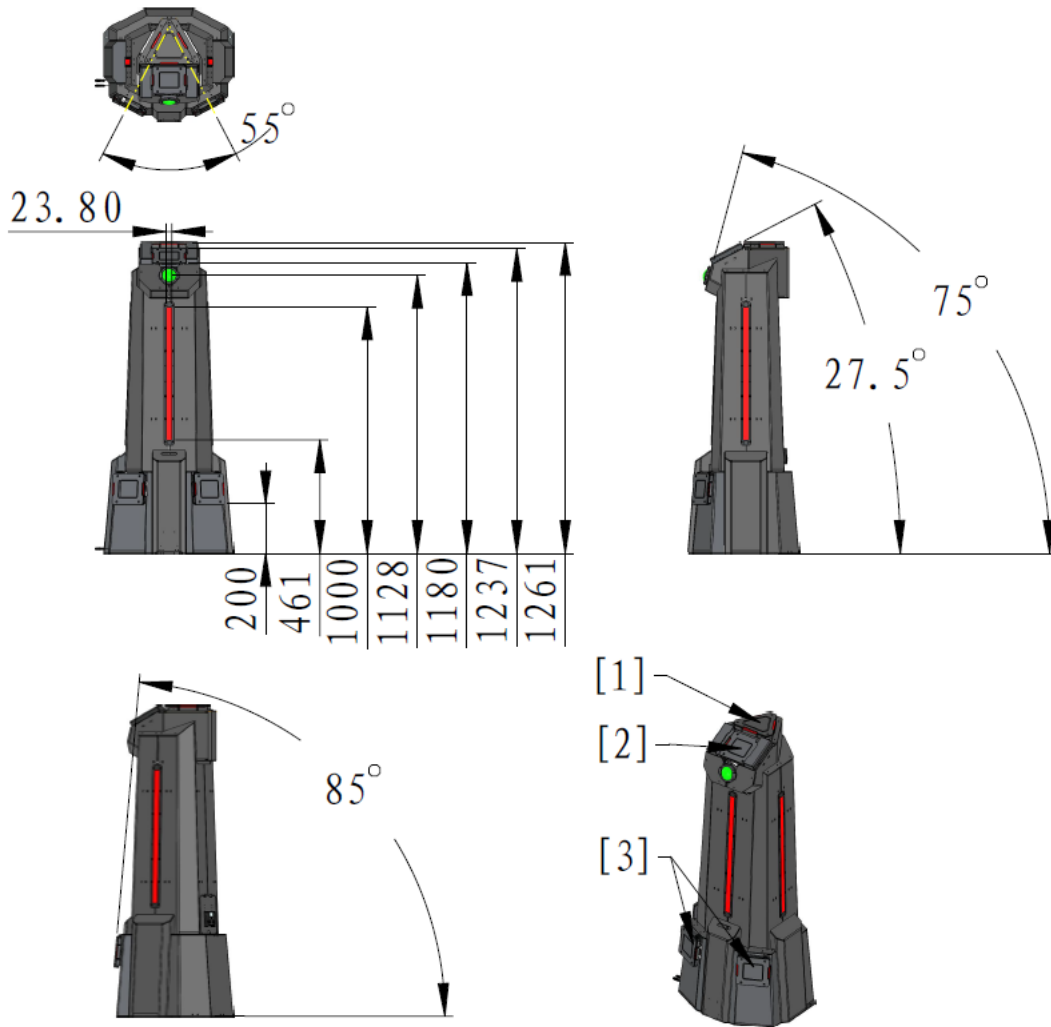

[1] Triangular Armor Module [2] Dart Detection Module [3] Small Armor Module

Figure 2-38 Dimensions of Outpost

2.4.2.1 Outpost Buff Point

The Outpost Buff Point is located near the Outpost, and its surface plane is around 15 mm from the Battlefield Ground.

2.4.3 Bumpy Roads

The Bumpy Roads are located in some parts of the Open Zone, having evenly spaced bumps on their surface.

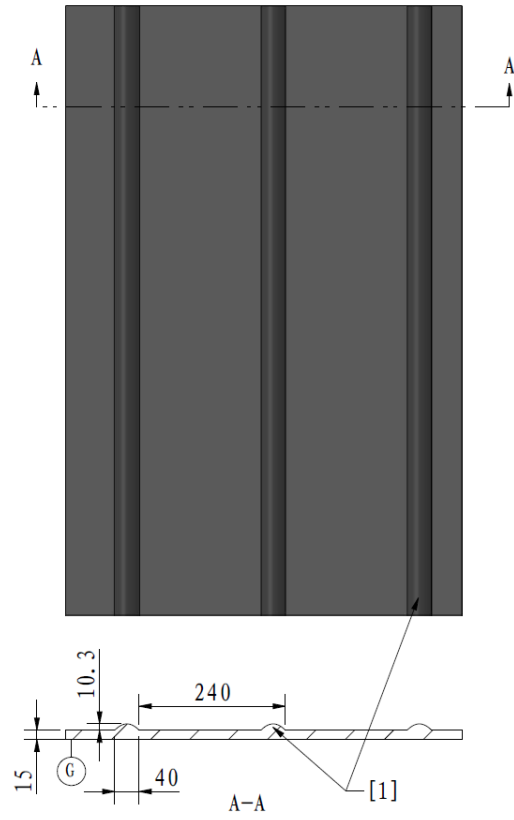

[1] Bump

Figure 2-39 Illustration of the bumps

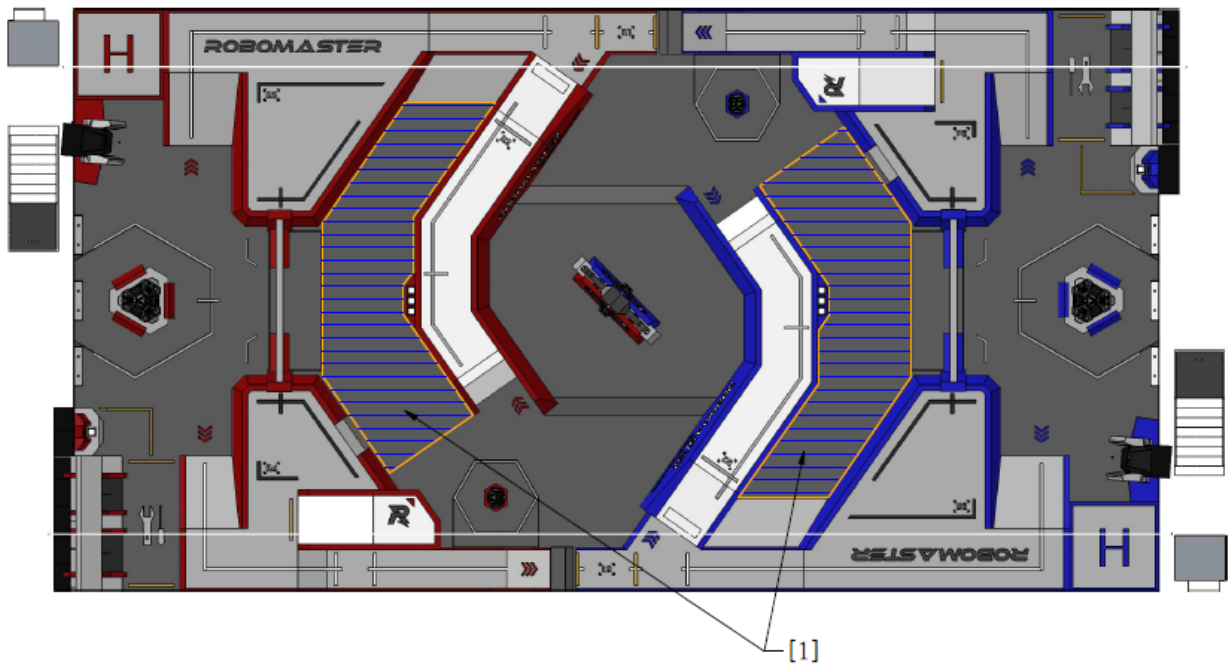

[1] Bumpy Roads

Figure 2-40 Bumpy Roads

2.5 Flight Zone

The Flight Zone is the flight area for Aerial Robots. It includes the Landing Pad and the air space above it as well as the air space above the road connected to the R3 Trapezoidal Elevated Ground.

2.5.1 Aerial Safety Rope

An Aerial Robot must be attached with an Aerial Safety Rope during a match to ensure the robot's safety. The robot's flight distance is restricted by the snap ring of the Aerial Safety Rope. The maximum total travel distance is 16 m.

2.6 Miscellaneous

2.6.1 Obstacle Block

Obstacle blocks are right triangular prisms with the dimensions of 1,000*280*200mm. They are located near the Base of one's team. Each team has 3 obstacle blocks, which robots can use to pave roads to help other robots go up and down a ramp or Launch Ramp.

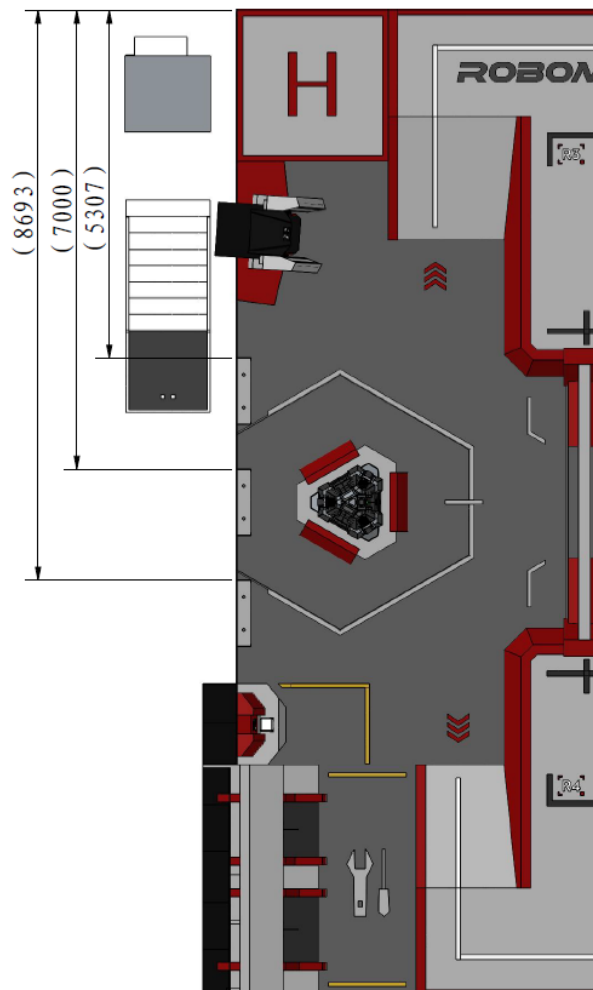

Figure 2-41 Initial position of an obstacle block

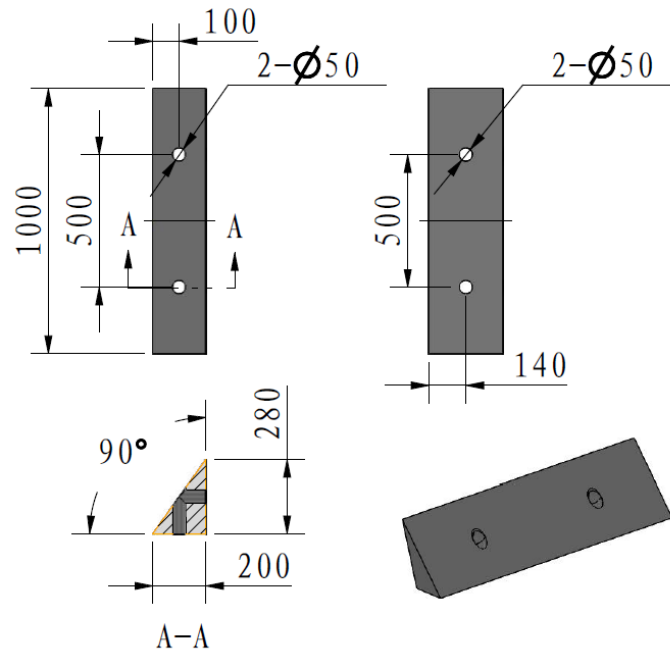

Figure 2-42 Obstacle block

2.6.2 Projectiles

Robots attack the Armor Modules of enemy robots by launching projectiles, causing damage to their HP so as to ultimately defeat them. The parameters and scenarios of use for projectiles in the competition are as follows:

Table 2-1 Projectile Parameters and Scenarios of Use

Robot Type	Appearance	Color	Size	Weight	Shore Hardness	Material	Scenarios of Use
42mm projectile	Similar to a golf ball	White	42.5 mm ± 0.5 mm	41 g ± 1 g	90 A	Plastic (TPE)	Some matches in the Regional Competitions and Final Tournament
17mm Fluorescent Projectile	Spherical	Yellow-green	16.8 mm ± 0.2 mm	3.2 g ± 0.1 g	90 A	Plastic (TPU)	The entire RMUC 2021

2.6.3 Minerals



The graphics on the mineral will later be changed and updated.

An mineral is an EVA cube with beveled edges and the dimensions of 200*200*200mm.

Small Resource Island Minerals:

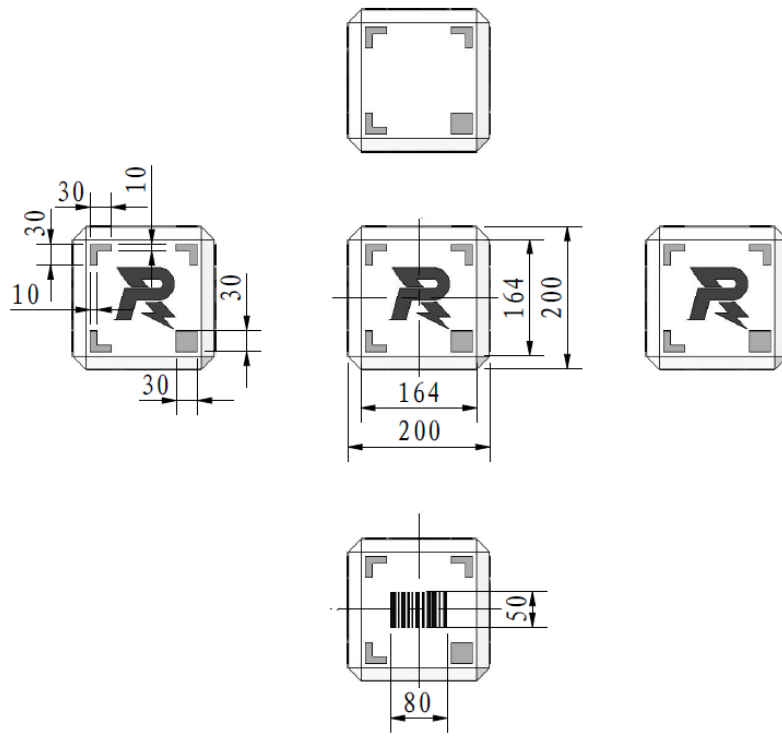

Figure 2-43 Small Resource Island Minerals

Resource Island Minerals:

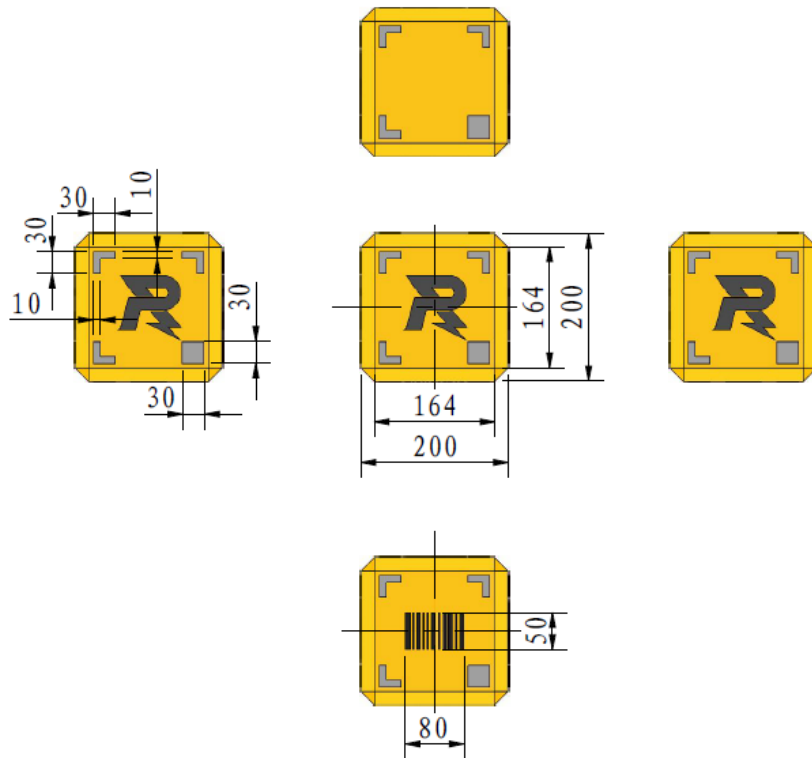

Figure 2-44 Resource Island Minerals

2.6.4 Engineer Rescue Card

The size of an Engineer Rescue Card is 110*90mm. It can be used for speeding up the revival process of one team's robots.

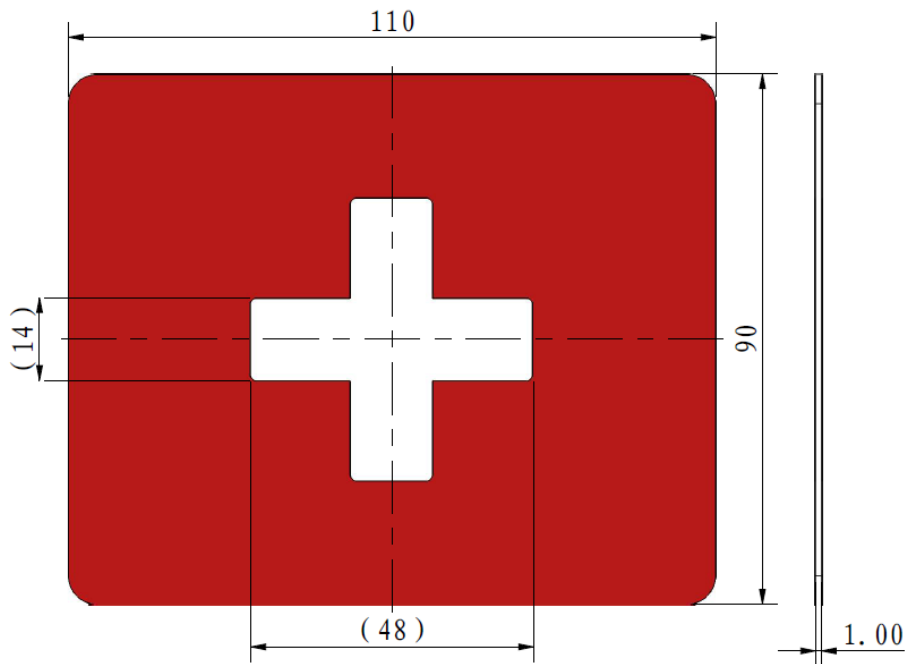

Figure 2-45 Engineer Rescue Card

2.6.5 Localization Points

There are several points in the battlefield that enable the localization of robots. Each localization point is attached with a visual tag with patterns that are non-recurring and asymmetrical from all angles.

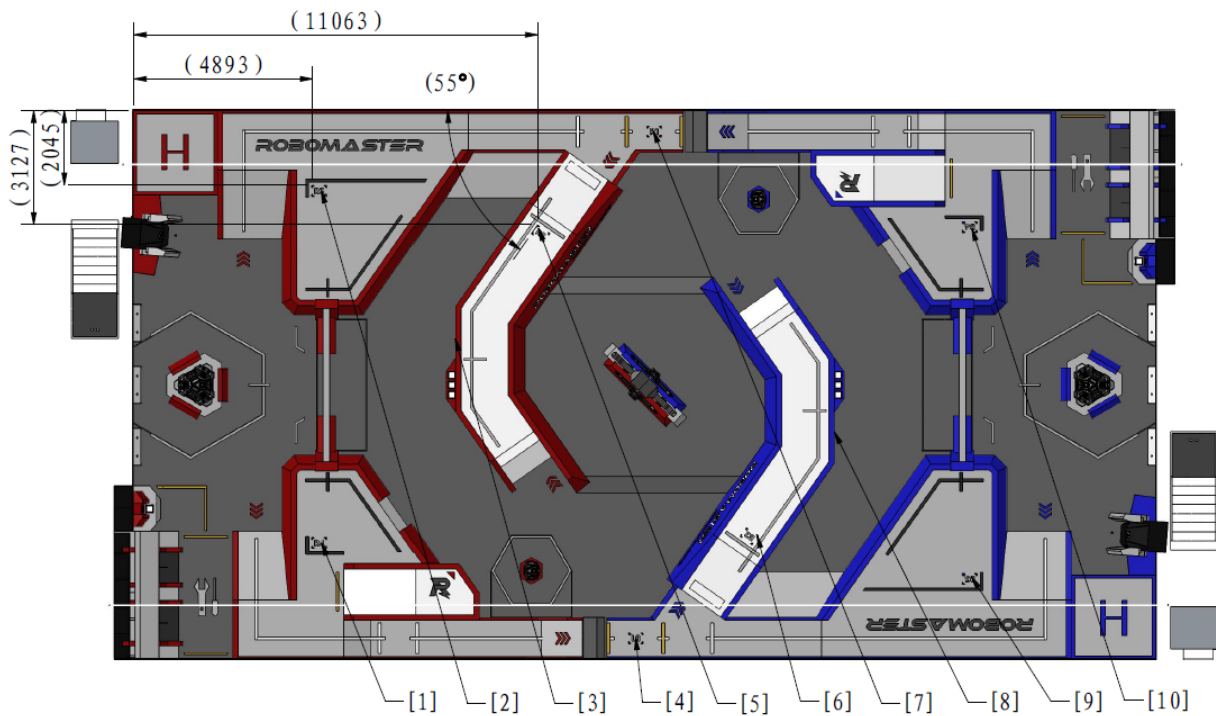

Figure 2-46 Localization points

Table 2-2 Coordinates of localization points

No.	1	2	3	4	5	6	7	8	9	10
Numbering	R4	R3	R0	B1	R2	B2	R1	B0	B3	B4
X	4890	4890	8800	13950	11060	16940	14050	19200	23110	23110
Y	-11690	-2400	-	-14580	-3130	-11880	-420	-	-12960	-3330
Z	-700	-700	-	-900	-500	-500	-900	-	-700	-700
Included angle	0°	0°	-	180°	35°	105°	0°	-	180°	180°



The origin of the coordinates is the corner of the Red Team's Landing Pad near the perimeter wall. The coordinates of each localization point are the distance from the upper left of that point to the origin of the coordinates. The included angle of a localization point is the angle formed by that point and the R3 localization point.

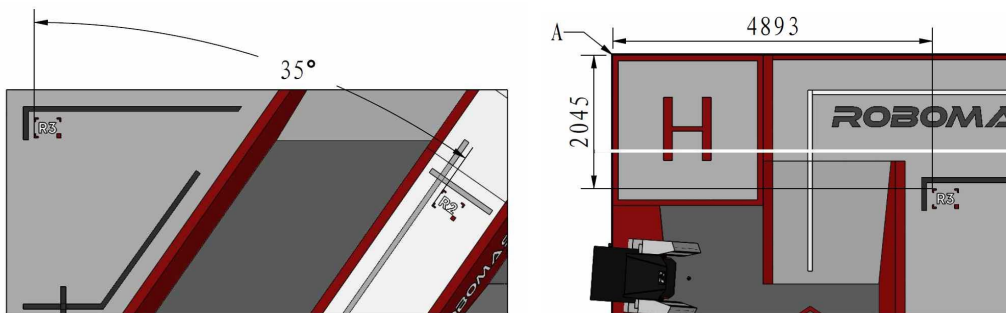

Figure 2-47 Illustrations of origin of coordinates and included angle

2.6.6 Operator Room

Operator Room lies outside the Battlefield and is an area for Operators during the competition. Operator Room consists of Main Operator Room and Pilot Room. Each Operator Room shall be equipped with a corresponding number of computers, each connected to its corresponding official equipment such as a monitor, mouse, keyboard, USB hub and wired headset. The Gimbal Operator is equipped with two displays, one showing the video-transmitted images from the Aerial Robot and the other showing the source images transmitted from the Radar. The Pilot Room is located in an area near the Landing Pad outside the Battlefield, as shown in "Figure 2-4 - Battlefield Modules".

3. Competition Mechanism

3.1 Robot Status and Buff Types

Robots will display the following statuses during the competition as shown below:

Table 3-1 Robot Status

Status	Description
Survive	Robot's HP is not zero.
Defeated	Where a robot's HP drops to zero after its Armor Module has been attacked or hit; it has exceeded its Chassis Power Consumption limit, Initial Firing Speed limit or Barrel Heat limit; its Referee System module has gone offline, etc.
Ejected	Where a robot is ejected directly by the Referee System as a penalty after being issued with a Red Card or having accumulated 8 violation points.
Offline	Where a robot is disconnected from the server.

A robot is deemed "destroyed" if its Armor Module is attacked by an enemy robot until its HP drops to zero. The destruction of a robot is determined in one of the following two ways:



- Where a robot defeats an enemy robot with a critical hit, the latter is considered destroyed
- If a robot is attacked by multiple enemy robots within 10 seconds before its destruction or ejection, then the last of the enemy robots to attack the defeated robot will be deemed the destroying robot



After a robot is defeated or ejected, the Referee System will cut off power supply to the robot (except for the Mini PC).

Robots can earn buffs by completing specific missions. The types of buffs are as follows:

Table 3-2 Robot buffs

Buff Type	Description
Attack buff	Increases the damage caused by a projectile attack.
Defense buff	Reduces the damage suffered from a projectile attack or impact.  Defense buffs are not applicable to HP deductions caused by penalties, the Referee System going offline, exceeding limits, etc.
Barrel heat cooling buff	Increases the barrel heat cooling rate per second.
Buffer energy buff	Receives extra buffer energy for chassis power.
HP recovery buff	The robot restores its HP by a certain amount each second, until it reaches its Maximum HP.

3.2 HP Deduction Mechanism

The HP of ground robots and Sentry Robots will be deducted in any of the following situations: the Barrel Heat limit, Initial Firing Speed limit or Maximum Chassis Power Consumption of a Launching Mechanism is exceeded; an Armor Module is attacked by a projectile or strike; an important module of the Referee System goes offline; penalty for violation of rules; etc.

The Referee System will round down the HP deduction and keep the integer when calculating the HP.

3.2.1 Initial Firing Speed Exceeds the Limit

Set the Initial Firing Speed limit as V_0 (m/s), the actual initial speed detected by the Referee System as V_1 (m/s).

When $V_1 > V_0$, if it is a 17mm projectile, the deducted HP = Maximum HP * L%. If it is a 42mm projectile, the deducted HP = Maximum HP * M%. The values of L% and M% are correlated to the margin of excess. The larger the margin of excess, the greater the values of L% and M%.

Table 3-3 Penalty Mechanism for Exceeding Initial Firing Speed Limit

17mm projectile	L%	42mm projectile	M%
$0 < V_1 - V_0 < 5$	10%	$V_0 < V_1 \leq 1.1 * V_0$	10%
$5 \leq V_1 - V_0 < 10$	50%	$1.1 * V_0 < V_1 \leq 1.2 * V_0$	20%
$10 \leq V_1 - V_0$	100%	$1.2 * V_0 < V_1$	50%

3.2.2 Barrel Overheating and Cooling

Set the Barrel Heat limit as Q_0 , the current barrel heat as Q_1 , For each 17mm projectile detected by the Referee System, the current barrel heat Q_1 is increased by 10 (regardless of its initial speed) For each 42mm projectile detected, the current barrel heat Q_1 is increased by 100 (regardless of the 42mm projectile's initial speed). The barrel cools at a frequency of 10 Hz. The cooling value per detection cycle = cooling value per second / 10.

A. and when $Q_1 > Q_0$, the first-person-view (FPV) visibility on the robot Operator's screen is reduced. The FPV will only return to normal when $Q_1 < Q_0$. The FPV for the client is as follows:

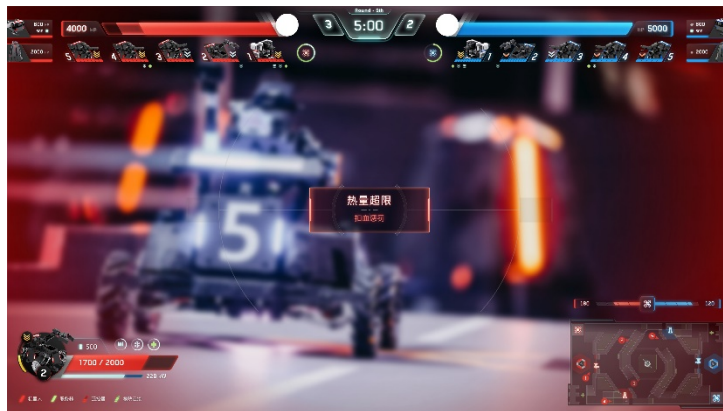

Figure 3-1 FPV of Client

- B. When $2Q_0 > Q_1 > Q_0$, the deducted HP for every 100 ms = $((Q_1 - Q_0) / 250) / 10 * \text{Maximum HP}$. After the HP deduction, the barrel cooling will be calculated.
- C. When $Q_1 \geq 2Q_0$, the immediate deducted HP = $(Q_1 - 2Q_0) / 250 * \text{Maximum HP}$. After deducting HP, set $Q_1 = 2Q_0$.

The below shows the HP deduction and cooling logic when the Barrel Heat limit is exceeded:

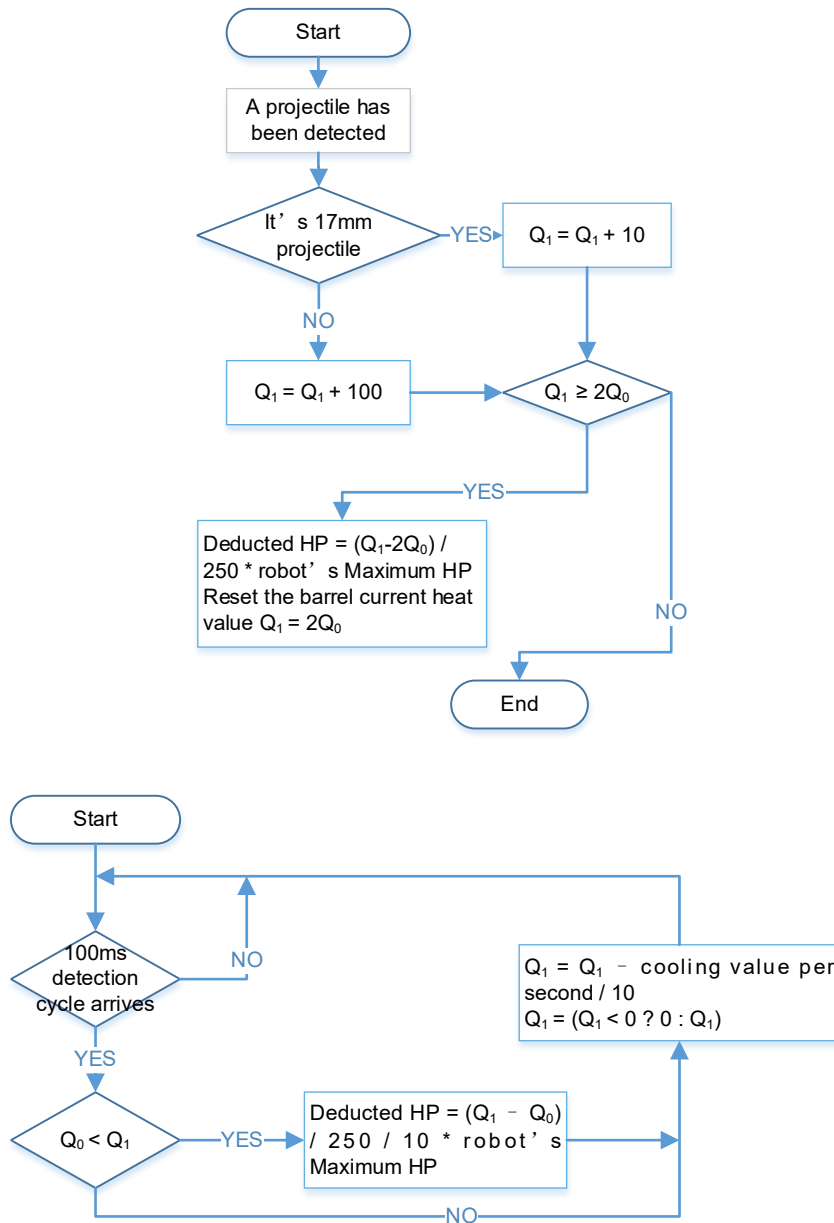

Figure 3-2 (Above) HP Deduction logic and (Below) cooling logic when Barrel Heat limit is exceeded

3.2.3 Exceeding Chassis Power Consumption Limit

The chassis power consumption of robots will be continuously monitored by the Referee System, and the robot chassis needs to run within the chassis power consumption limit. Considering it is difficult for a robot to control instantaneous output power when in motion, a buffer energy (Z) has been defined to avoid the consequent penalty. The buffer energy (Z) of Sentry is 200J; while the Z values of Standard or Hero may differ according to these two scenarios:

- If Standard or Hero has not triggered the Launch Ramp Buff, its buffer energy limit is 60J.
- If Standard or Hero has triggered the Launch Ramp Buff, its buffer energy limit increases to 250J. If the buffer

energy reaches below 60J after subsequent consumption, it can be restored up to 60J. Refer to "3.7.3 - Launch Ramp Buff Mechanism" for details on the Launch Ramp buff mechanism.

Standard and Hero:

After the buffer energy has been depleted, if the Chassis Power Consumption of a Standard or Hero Robot exceeds the limit, the deducted HP in each detection cycle = Maximum HP * N% * 0.1.

The Referee System monitors chassis power consumption at a frequency of 10 Hz.

Excess Percentage: $K = (P_r - P_l) / P_l * 100\%$, where P_r is the instantaneous Chassis Power Consumption output and P_l is the power consumption limit.

Table 3-4 Penalty Mechanism for Exceeding Chassis Power Consumption Limit

K	N%
$K \leq 10\%$	10%
$10\% < K \leq 20\%$	20%
$K > 20\%$	40%

For example: If the Maximum Chassis Power Consumption of a Hero Robot has been upgraded to 60W and its Maximum HP to 350, while maintaining a continuous power output of 120W without triggering the Launch Ramp Buff, then the 60J of buffer energy will be fully consumed after one second. The excess percentage that can be calculated in the next 100 ms detection cycle, $K = (120 - 60) / 60 * 100\% = 100\%$. Since $K > 20\%$, the deducted HP = $350 * 40\% * 0.1 = 14$.

The logic graph for chassis power consumption detection and HP deductions for a Standard or Hero Robot is shown below:

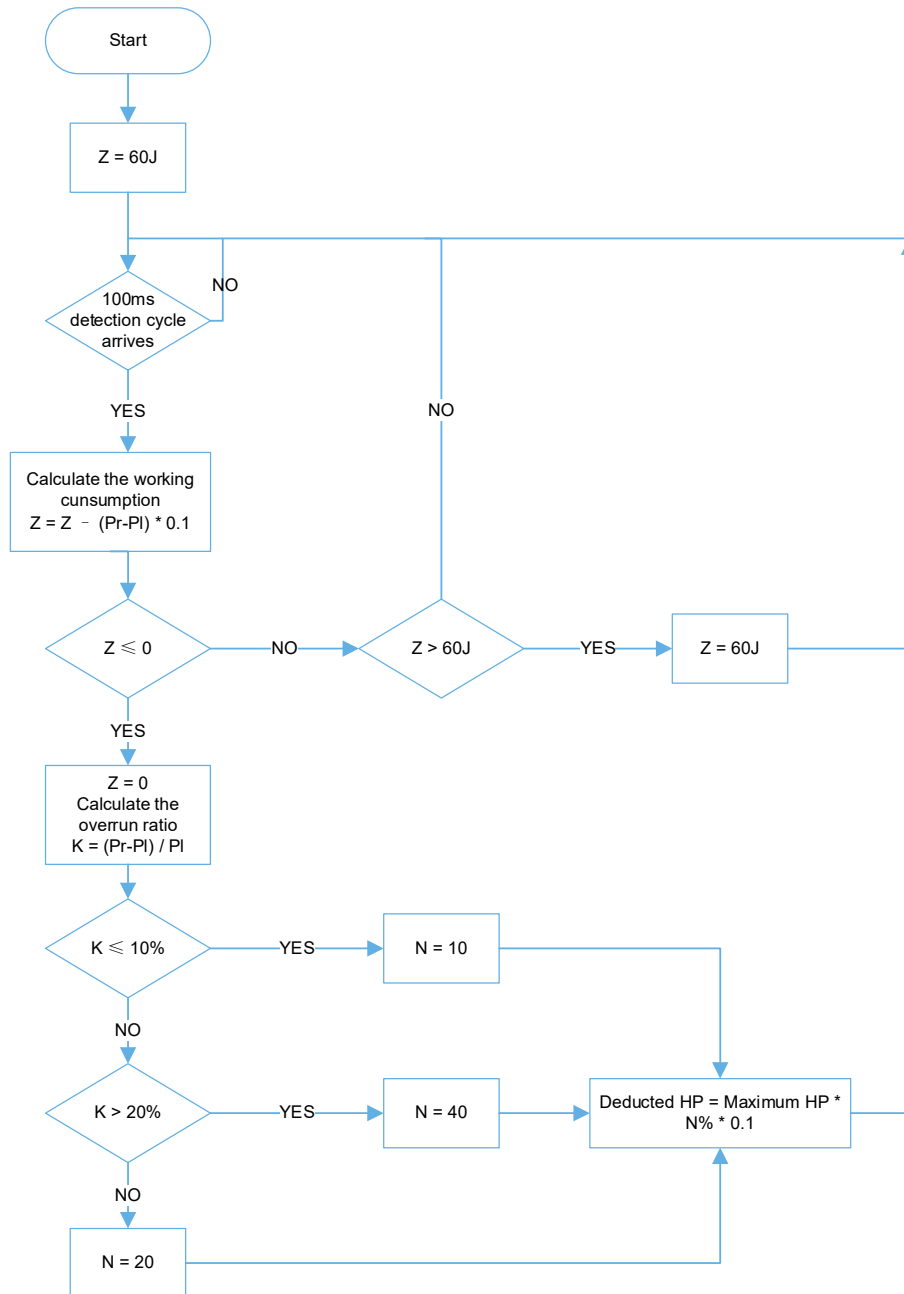

Figure 3-3 Chassis Power Consumption Detection and HP Deduction Logic of Standard and Hero

Sentry:

After the buffer energy is depleted, if the chassis power consumption of a Sentry Robot exceeds the limit, the Referee System will temporarily shut down the chassis' power output.

The logic graph for chassis power consumption detection of Sentry and chassis power-off is shown below:

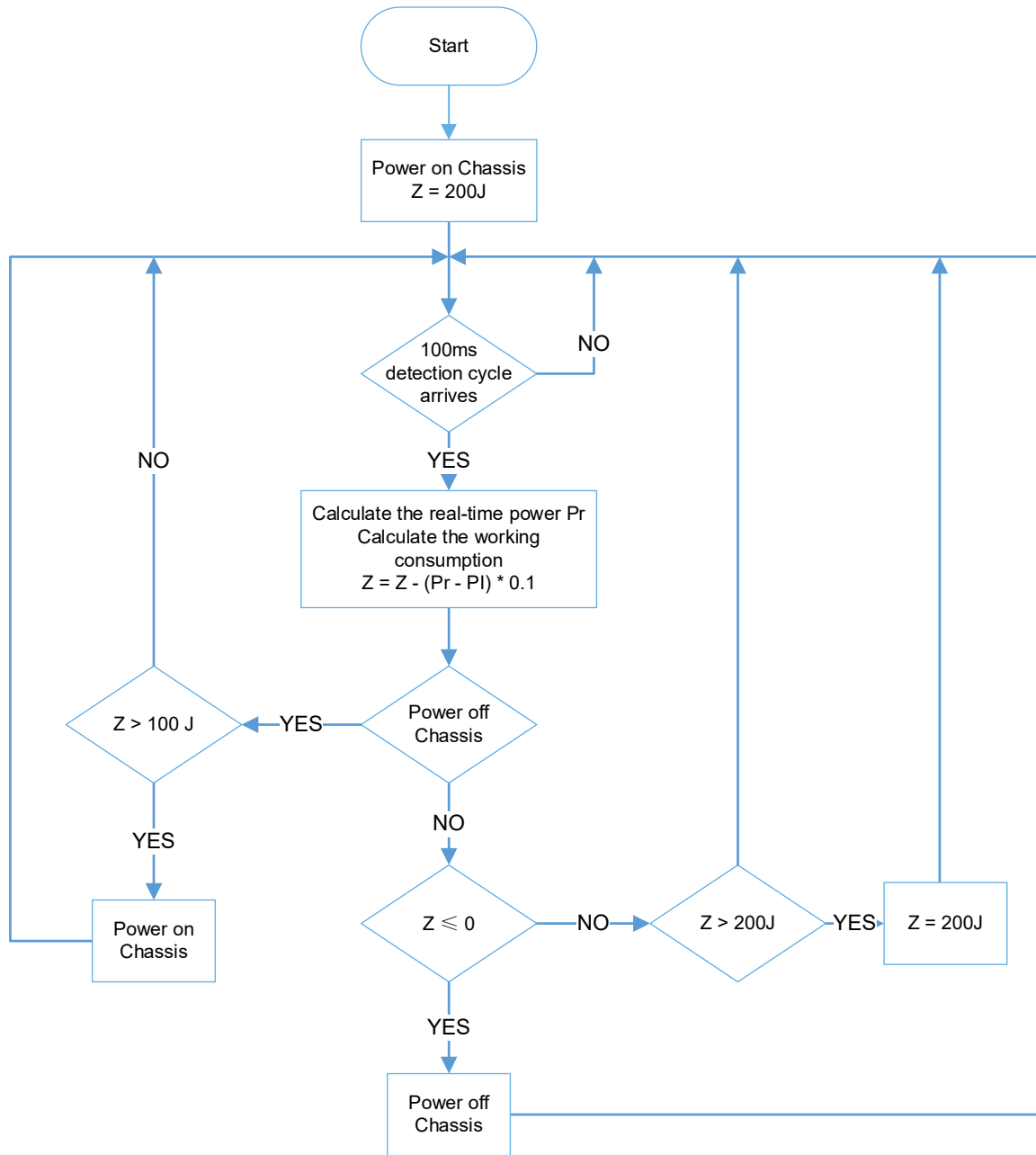

Figure 3-4 Chassis Power Consumption Detection and Chassis Power-off Logic of Sentry

3.2.4 Attack Damage

An Armor Module detects projectile attacks using the pressure sensor combined with the armor's vibration frequency. A Dart Target Module detects dart attacks using the Armor Module combined with the phototube. A Dart Detection Module can detect attacks from darts and 42mm projectiles. The time interval required for the detection of a dart attack by a Dart Detection Module is 1 second.

The shortest detection interval for an Armor Module is 50 ms (when hitting an Armor Module using a 42mm projectile, the detection interval can be extended to a maximum of 200 ms).

The projectile needs to come into contact with the impact surface of the armor module at a certain speed in order to be successfully detected. The velocity range for the detection of different projectile types by an armor module is as follows:

Table 3-5 An armor module's detection speed for different projectile types

Armor Module	17mm projectile	42mm projectile
Large Armor Module, Small Armor Module	Higher than 12m/s	Higher than 8m/s
Triangular Armor Module	Not detected	Higher than 6m/s



In an actual match, the normal speed of a projectile that touches the Armor Module attack surface is different from its initial firing speed due to the projectile's speed decay and its incident angle not being normal to the Armor Module attack surface. Damage detection is based on the normal component of the projectile's speed upon contact with the Armor Module attack surface.

A robot experiences damage when its Armor Module is struck. However, a robot is not allowed to cause HP damage to the other side's robots through striking (including collision with the robots or launching objects).

The table below sets out the HP deductions for different armors assuming no buff points are received:

Table 3-6 HP Deduction Mechanism for Attack Damage

Damage Type	HP Damage Value
42mm projectile	<ul style="list-style-type: none"> ● Robot's Armor Module: 100 ● Base and Outpost Armor Modules: 200 ● Triangle Armor Module of the Base and Outpost: 300
17mm projectile	<ul style="list-style-type: none"> ● Robot's Armor Module: 10 ● Base and Outpost Armor Modules: 5
Collision	2
Dart	1/5 of the Maximum HP of Base or Outpost

3.2.5 Referee System Going Offline

According to the latest version of the "RoboMaster 2021 University Series Robot Building Specifications Manual", robots must be mounted with their corresponding Referee System Modules, and each Referee System Module must have a stable connection to its server throughout the competition. The Referee System server detects the connectivity of each module at a frequency of 2 Hz. If important Referee System modules such as a Speed Monitor Module, Positioning System Module or Armor Module goes offline due to design or structural problems, then the HP of the corresponding ground robots and Sentry will be deducted.

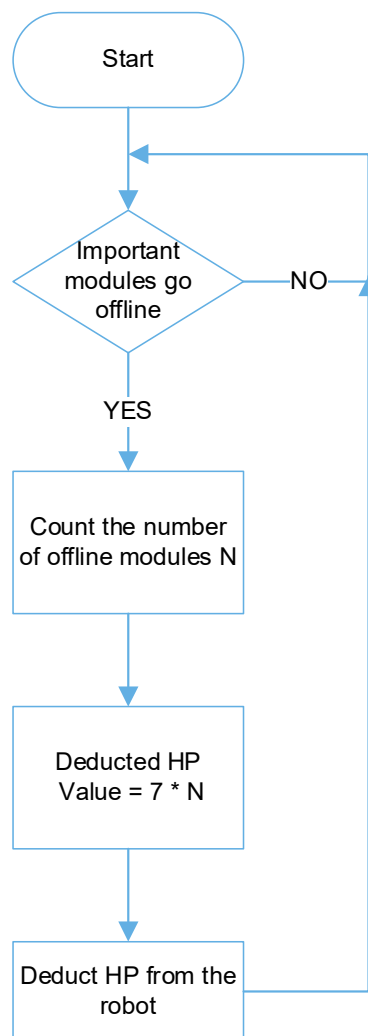

Figure 3-5 HP Deduction Mechanism for Important Referee System Modules Going Offline

3.2.6 Irregular Offline Status

During the competition, if a robot enters an "irregular offline" status:

- For less than 30 seconds: It can reconnect back to the competition and its experience and levels will still be

counted during the offline period.

- For more than 30 seconds: It cannot reconnect back to the competition and be revived for that round of the match.

Table 3-7 Consequences of irregular offline status

Robot Type	Consequences of irregular offline status
Standard and Hero Robots	<ul style="list-style-type: none"> ● The power supply to the Launching Mechanism and Chassis is cut off, and the Maximum HP is deducted by 5% each second until it gets to zero. ● The RFID Interaction Module is disabled. ● The robot no longer detects any damage caused by collision or projectile attacks.
Engineer Robot	<ul style="list-style-type: none"> ● The power supply to the Launching Mechanism and Chassis is cut off, and the Maximum HP is deducted by 5% each second until it gets to zero. ● The RFID Interaction Module and RFID Interaction Module Card are disabled. ● The robot no longer detects any damage caused by collision or projectile attacks.
Sentry Robot	<ul style="list-style-type: none"> ● The power supply to the Launching Mechanism and Chassis is cut off, and the Maximum HP is deducted by 5% each second until it gets to zero. ● The robot no longer detects any damage caused by collision or projectile attacks.
Aerial Robot	The power supply to the Launching Mechanism is cut off, and robots can no longer call for air support.



The HP deduction caused by a robot's "irregular offline" status does not count towards the other team's damage HP.

3.3 Economic System

During the match, both teams will receive gold coins regularly. They can also mine for additional coins. The gold coins can be used to redeem projectiles, call for air support, redeem 42mm projectile allowance for Hero Robots, etc.

Each team has 200 coins at the start of the match. For every following minute, 100 gold coins will be given to each team until the fifth minute (when countdown is at 1:59). Both teams will receive 200 gold coins at the sixth minute

(when countdown is at 0:59).

Each mineral from the Small Resource Island can be exchanged for 75 gold coins. Each mineral from the Resource Island can be exchanged for 300 gold coins.

Table 3-8 Item redemption rules

Item name	Redemption ratio	Redemption limit
17mm projectile	50 coins/50 rounds	1500
42mm projectile	75 coins/5 rounds	100
Air support	400 coins/time After air support has been requested, the Aerial Robot will be able to launch 500 rounds of 17mm projectiles over 30 seconds (no coins need to be spent for the projectiles)	3

3.3.1 17mm Projectile Redemption Mechanism

No projectiles need to be purchased for Automatic Standard Robots at the Official Projectile Supplier. They can be pre-loaded with a certain amount of 17mm projectiles before the competition. During the match, the Referee System will automatically deduct one gold coin from the relevant team for each launched 17mm projectile detected. If the amount of gold coins deducted reaches 500, the power supply to the Launching Mechanism will be cut off.

Ground Robots can exchange their gold coins at the Official Projectile Supplier for 17mm projectiles. The operator reloads projectiles through the client interface using a keyboard and mouse. Projectiles can be reloaded on robots after the match has started. If the operator decides to supply projectiles, he or she should press the "O" key on the keyboard. If a team has remaining gold coins and their robot has detected an RFID Interaction Module Card below the Supplier Zone, the projectile redemption quantity can be selected directly on the redemption panel to complete the exchange process. If a team has remaining gold coins but their robot's RFID Interaction Module has not detected any RFID Interaction Module Card below, projectiles can be redeemed by initiating the "force projectile redemption" command. After the redemption is completed, the Official Projectile Supplier will automatically release the corresponding quantity of projectiles.

3.3.2 42mm Projectile Allowance Redemption Mechanism

3.3.2.1 Initial Loading of 42mm Projectiles

During the Three-Minute Setup Period, the referee will issue 100 rounds of 42mm projectiles to both teams, who

may then load any number of the projectiles on their Engineer or Hero Robots.

3.3.2.2 42mm Projectile Allowance

The 42mm projectile allowance for a Hero Robot indicates the amount of 42mm projectiles the Hero Robot is currently allowed to launch. For each round of 42mm projectile launched, the projectile allowance reduces by 1 round. If the projectile allowance becomes zero, the power supply to the 42mm Launching Mechanism of the Hero Robot will be cut off. If a team's Hero Robot has occupied its Restoration Zone, the operator may redeem projectile allowance through the client interface. For specific operational details, refer to "3.3.1 17mm Projectile Redemption Mechanism".

3.3.3 Air Support Redemption Mechanism

If a team's gold coin amount reaches or exceeds 400, the operator may press the "H" button on the keyboard to redeem the coins for air support.

3.4 Battlefield-Related Mechanism

3.4.1 Base and Outpost HP

Base HP is 5000. Outpost HP is 2000.

3.4.2 Relevant Mechanisms on Minerals

The Small Resource Island has three fixed grooves, on which its minerals are placed.

Five minerals are hung from the top of the Resource Island. Their locations and numbering are as shown in "Figure 3-6 Numbering for minerals".

The Engineer may grab the minerals from the Small Resource Island and those released by the Resource Island.

In each round of the competition, the Resource Island will release its minerals in two batches. They are dropped 15 seconds and 3 minutes after the start of the round respectively. The minerals released in the first batch are No. 2 and 4, while the remaining three are in the second batch. Each mineral in a batch is dropped randomly at a 5 seconds' interval. The numbering for the minerals is as shown below:

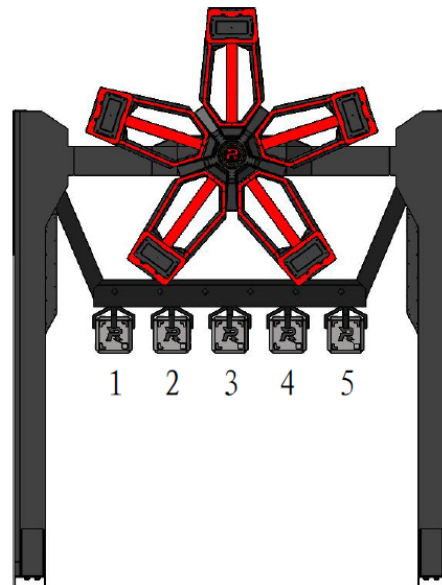

Figure 3-6 Numbering for minerals

3.4.3 Power Rune Mechanism



After successfully activating the Power Rune, the HP damage value of darts remains unchanged. See "Table 3-6 - Attack Damage HP Deduction Mechanism".

3.4.3.1 Mechanism Overview

The Power Rune is located at the center of the Battlefield. It can be activated by being hit with a projectile. The whole team will receive a certain amount of buff points once it is activated.

The Red Team can only activate the Red Team's Power Rune while the Blue Team can only activate the Blue Team's Power Rune. Both sides can strike the Power Rune at the same time. If one side's Power Rune has entered the active state, the other side's Power Rune becomes unavailable.

The Power Rune consists of two stages: the Small Power Rune and Large Power Rune

- **Small Power Rune:** One minute into the match until the fourth minute (i.e., countdown at 5:59-4:00), the Power Rune starts rotating and becomes available. After the robot from one side successfully activates the Small Power Rune, all robots of the side gain a 1.5-time attack buff.
- **Large Power Rune:** Four minutes into the match (i.e. countdown at 2:59), the Power Rune starts rotating and becomes available. After the robot from one side activates the Large Power Rune, all robots of the side gain a double attack buff and 50% defense buff.

The duration of the Power Rune's buff effect is 45 seconds. After the buff effect of the Power Rune has lapsed, the Power Rune will enter into an unavailable state for 30 seconds. The unavailable state of a Small Power Rune after its buff effect has lapsed will not affect the Large Power Rune entering the available state.

3.4.3.2 Rotation Strategy

The Power Runes of both teams rotate on the same axis, i.e. the red team's Power Rune rotates in the clockwise direction while the blue team's Power Rune rotates in the counterclockwise direction (as per the rotation direction when facing the respective team's Power Rune). Before the start of a round, the Power Runes rotate in a random direction. During the round, the Power Runes rotate in a consistent direction.

The rotating speed of a Small Power Rune is set at 10 rpm.

The rotating speed of a Large Power Rune changes cyclically based on a trigonometric function. The target function for speed is: $\text{spd}=0.785*\sin(1.884*t)+1.305$, where the unit of "spd" is rad/s, the unit for "t" is s, and "t" is reset as 0 every time the Large Power Rune enters the available state.

The margin of error for time between the actual spinning speed of the Large Power Rune and the objective speed function is within 500 ms.

3.4.3.3 Status

The Power Rune has five statuses: Unavailable, Available, Activating, Activated and Activation Failed.

1. Unavailable

Within the first minute of the match (i.e. countdown at 7:00-6:00), the fourth minute of the match (i.e. countdown at 3:59-3:00) and the 30 seconds after each lapse of the Power Rune buff effect, the Power Rune is unavailable as shown below:

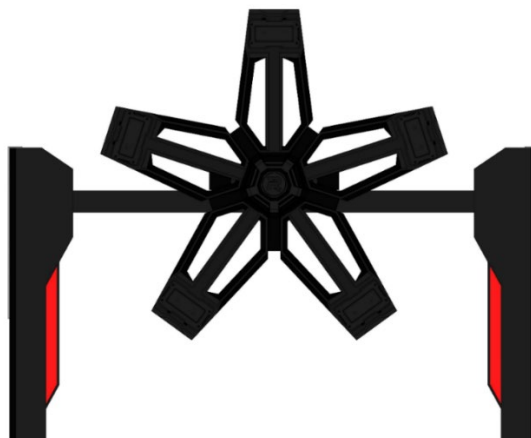

Figure 3-7 Power Rune When Unavailable

2. Available

After the first minute until the third minute of the match (i.e. countdown at 5:59-4:00) and four minutes into the match (i.e. countdown at 2:59), the Power Rune enters the available state as shown below:

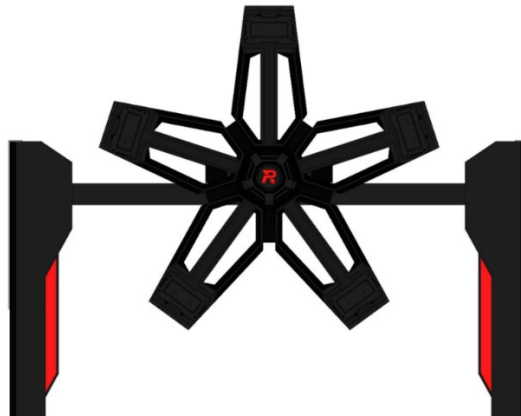

Figure 3-8 Power Rune When Available

3. Activating

When the Power Rune is available, a Standard or Hero Robot that occupies the Power Rune Activation Point and stays there for 3 seconds or longer will launch the Power Rune into the activating state (see "Figure 3-9 Power Rune when activating State"). The arrow light effects on the mounting bracket of any of the 5 Armor Modules will be turned on at random. If a projectile manages to hit the Armor Module within 2.5 seconds, its mounting bracket will be completely lit up. At the same time, the Power Rune will randomly illuminate one of the remaining four armor modules, so on and so forth, as shown below:

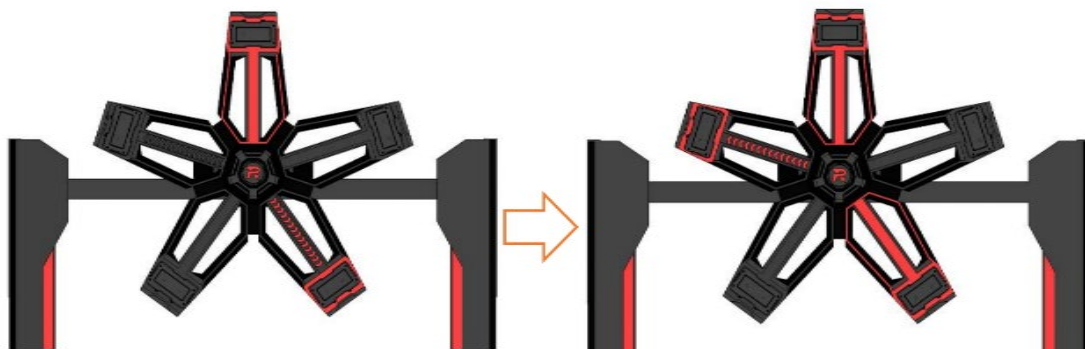

Figure 3-9 Power Rune when activating

4. Activated

If all five mounting brackets are illuminated, the Power Rune is then activated as shown below:

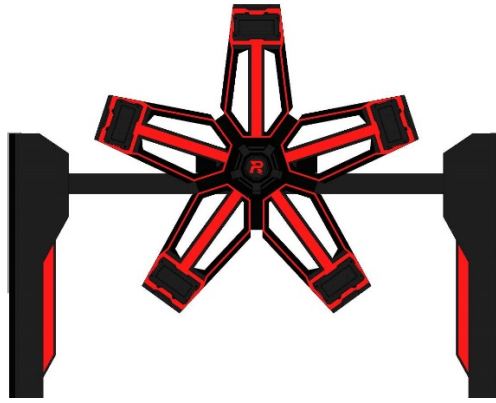

Figure 3-10 Power Rune When Activated

5. Activation Failed

If any of the following conditions occur during activation, the activation will fail and the Power Rune become available for activation again.

- Failure to hit a randomly lit Armor Module within 2.5 seconds
- A non-randomly lit Armor Module is hit

3.5 Relationship between a Sentry Robot, Outpost and Base

If the Outpost of one side has been destroyed, 100% of the defense buff of its Sentry and the Invincible status of its Base will be disabled, and the Virtual Shield will be activated.

Where an Outpost has been destroyed, and if the Sentry has not entered the Battlefield, been destroyed or ejected, the Armor of their Base will be expanded and the Virtual Shield will be disabled.

When an Outpost is intact, the dart guiding light on the Outpost is on, the dart guiding light on the Base is off. When the Outpost is destroyed, the dart guiding light on the Outpost is off, the dart guiding light on the Base is on.

3.6 Virtual Shield Mechanism



The HP of virtual protective shields cannot be restored, and the HP deduction suffered by a virtual protective shield from being attacked will be included in the damage HP of the other team.

After the Invincible status of Base has been removed and Sentry of this side still survives, the Virtual Shield of the Base will be enabled and have 500 HP. When a robot attacks the enemy's Base, the HP of its Virtual Shield will first be deducted. If the Virtual Shield's HP has reduced to zero, the Base's HP will be deducted.

3.7 Battlefield Buff Mechanism



Occupied: When a robot has reached a Buff Point area and its RFID Interaction Module has detected the RFID Interaction Module Card in the area.

All Buff Point areas in the Battlefield are shown below:

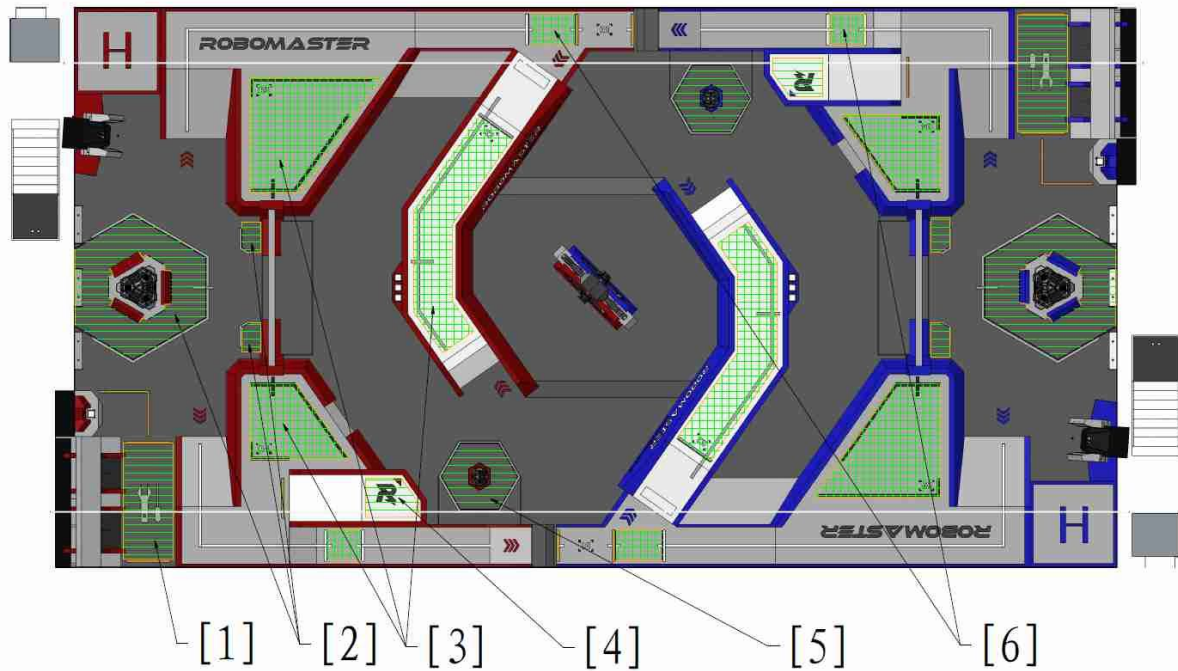

- | | | | | | |
|-----|---|-----|--------------------|-----|----------------------------------|
| [1] | Restoration Zone | [2] | Base Buff Points | [3] | Elevated Ground Buff Point |
| [4] | Power Rune Activation Point and Hero Robot Sniper Point | [5] | Outpost Buff Point | [6] | Launch Ramp Buff Detection Point |

Figure 3-11 Battlefield Buff Point Area

All Buff Point areas are laid with multiple RFID Interaction Module Cards. A Buff Point area can be occupied at the same time by multiple robots of one team. There may be a 2-second delay in the taking effect and expiration of occupation. If the occupying robot has been defeated, the buff gained will expire.

An Engineer Robot cannot receive any site buffs other than Restoration Zone buffs.

3.7.1 Base Buff Points Mechanism

Base Buff Points are located in the hexagonal area around the Base and the area behind the Bunker under the Sentry

Rail.

- Robots that occupy the hexagonal area around their own team's Base will gain a 50% defense buff and 3-time barrel heat cooling buff.
- Robots that occupy the area behind the Bunker under the Sentry Rail will gain a 5-time barrel heat cooling buff.

After a dart has hit the Base, the buff gained at the Base will disappear temporarily for 30 seconds. A Base Buff Point can only be occupied by robots of the team to which it belongs.

3.7.2 Elevated Ground Buff Mechanism



The occupied status of the Elevated Ground Buff Points of different zones are completely independent of and unrelated to one another.

Elevated Ground Buff Points are present on the R3 Trapezoidal, R4 Trapezoidal and R2 Ring-Shaped Elevated Grounds. A robot that occupies an Elevated Ground Buff Point receives a 5-time barrel heat cooling buff. If a robot of one side occupies an Elevated Ground Buff Point of one zone, no robots of the other side are allowed to occupy it at the same time.

3.7.3 Launch Ramp Buff Mechanism

There are two Launch Ramp Buff Detection Points on the respective roads for each team. A robot must detect the RFID Interaction Module Card of the two Launch Ramp Buff Detection Points of its team within 10 seconds, in order to trigger the buff from the Launch Ramp. The two Launch Ramp Buff Detection Points can be occupied by both teams. A robot that triggers a buff from the Launch Ramp receives:

- 50% defense buff for 20 seconds
- An increase of buffer energy to 250J (see "3.2.3 Exceeding Chassis Power Consumption Limit")
- 3-time buff for barrel heat cooling rate per second lasting 20 seconds

3.7.4 Outpost Buff Mechanism

When a team's Outpost is intact, any robot occupying the Outpost Buff Zone of the team will receive a 5-time barrel heat cooling buff.

After a Dart has hit the Outpost, the buff gained at the Outpost will disappear temporarily for 30 seconds.

3.7.5 Power Rune Buff Mechanism

When a team's Power Rune is in the available state, and any of its robots occupies its own Power Rune Activation Zone for 3 seconds or longer, the Power Rune will enter the activating state (see "Figure 3-9 Power Rune in Activating State") and the robot occupying the zone will receive a 5-time barrel heat cooling buff.

3.7.6 Restoration Zone Mechanism

A robot that occupies its team's Restoration Zone can receive buffs for reviving defeated robots or recovering the HP of surviving robots. For the details of their implementation and values, please refer to "3.9 HP Recovery and Revival Mechanism".

3.7.7 Hero Robot Sniper Point Mechanism

The Power Rune Activation Point of a team can provide Hero Robot Sniper Point buffs to its own Hero Robot. When the Hero Robot of a team occupies the buff point, the damage value inflicted on the other team's Outpost and Base by the Hero Robot using a 42mm projectile will be boosted by 2.5 times.

When the Base or Outpost of a team is attacked with a 42mm projectile by a Hero Robot occupying the sniper point, it will enter a 10-second defense period. During the defense period, the Outpost and Base of the team will receive a 100% defense buff for 42mm projectiles.

3.8 Mobile 17mm Launching Mechanism

A Mobile 17mm Launching Mechanism can be mounted on either one of the Aerial, Standard and Hero Robots, provided that it meets the technical specifications of all robots. All Launching Mechanisms must meet the relevant requirements for Initial Firing Speed Limit for Projectiles. Each Launching Mechanism can be mounted with a laser sight.

Example 1: A Standard Robot can be mounted with a 17mm Launching Mechanism. A team can mount a mobile 17mm Launching Mechanism on a Standard Robot as needed. The Robot will then have two 17mm Launching Mechanisms.

Example 2: An Aerial Robot does not have a Fixed Launching Mechanism. A team can mount a Mobile 17mm Launching Mechanism on an Aerial Robot as needed. The Robot will then have a 17mm Launching Mechanism.

The Barrel Heat of a Mobile 17mm Launching Mechanism is calculated separately from a Fixed Launching Mechanism. At the start of a match, the operator needs to select the type of Launching Mechanism for the Mobile 17mm Launching Mechanism.

3.9 Level-Up Mechanism

3.9.1 Experience System



Assist: Where a robot (not including the destroying robot) inflicts damage on the destroyed robot or Outpost within 10 seconds before its destruction.

At the beginning of the match, Standard and Hero are both at Level 1, and their performance level is zero. They upgrade themselves by gaining Value of Experience Points.

The Level Up mechanism during a match works as follows:

- If a Hero or Standard Robot is the destroying robot, it will receive the experience points corresponding to the value of experience points of the destroyed robot; otherwise, the latter's experience points will be distributed evenly among the surviving Hero and Standard Robots of the opposing team. The average is rounded up and shall be accurate to one decimal place.
- The Hero or Standard Robot assisting in the attack will receive 25% of the experience points corresponding to the value of experience points of the destroyed robot.
- When the first robot in a match is defeated, if the destroying robot is Hero or Standard, it will receive an extra 5 Value of Experience Points. Otherwise the 5 Value of Experience Points will be evenly distributed among the surviving Hero and Standard of the side gaining the First Blood. The average is rounded up and shall be accurate to one decimal place.

For example, when a Level 1 Standard has been destroyed, and if the destroying robot is Hero or Standard, it will gain 2.5 Value of Experience Points directly. Each assisting Hero or Standard will gain $2.5 * 25\% = 0.6$ Value of Experience Points.

In addition, a Standard gains 0.2 Value of Experience Points every 12 seconds, and Hero gains 0.4 Value of Experience Points every 12 seconds. If a Standard or Hero have been destroyed, their original Value of Experience Points will remain the same, but they will no longer gain any automatic Value of Experience Points during the time they are destroyed. Any excess Value of Experience Points after leveling up will be counted towards the next level.

Table 3-9 Levels and Experience Points for Standard, Hero, Sentry and Engineer Robots and Outpost

Robot Type	Level	Value of Experience Points	Value of Experience Points Required for Leveling Up
Standard Robot	1	2.5	3
	2	5	6
	3	7.5	-

Robot Type	Level	Value of Experience Points	Value of Experience Points Required for Leveling Up
Hero Robot	1	7.5	8
	2	10	12
	3	15	-
Sentry Robot	-	7.5	-
Engineer Robot	-	5	-
Outpost	-	5	-

3.9.2 Performance System

After the start of a match, the operators of the Standard and Hero Robots may select the types of chassis and Launching Mechanism for the robots. If a Standard or Hero Robot is to be installed with a Mobile 17mm Launching Mechanism, the type of Launching Mechanism will also need to be selected. After a selection has been made, it cannot be changed during a round. The performance of chassis and Launching Mechanisms is related only to the robot level.

No selections need to be made for Automatic Standard Robots as they are not controlled by operators. If an Automatic Standard Robot is installed with a Mobile 17mm Launching Mechanism, the attributes of the Launching Mechanism will remain the same as those of the fixed Launching Mechanism.

Table 3-10 Types of chassis and Launching Mechanisms

Robot Type	Chassis Type	Launching Mechanism Type
Standard Robot	HP-focused	Burst-focused
	Power-focused	Cooling-focused
	Balancing chassis	Projectile speed-focused
Hero Robot	HP-focused	Burst-focused
	Power-focused	Projectile speed-focused

Table 3-11 Attributes of Automatic Standard Robots

Level	Maximum HP	Maximum Chassis Power Consumption (W)	Barrel Heat Limit	Barrel Cooling Value per Second	Initial Firing Speed Limit (m/s)
1	200	120	120	40	30
2	300	120	180	60	30
3	400	120	240	80	30

Table 3-12 Attributes of Standard Robot Chassis

Chassis Type	Level	Maximum HP	Maximum Chassis Power Consumption (W)	Others	Remarks
Initial Status	0	100	40	-	-
Power-focused	1	150	60	-	-
	2	200	80	-	-
	3	250	100	-	-
HP-focused	1	200	45	-	-
	2	300	50	-	-
	3	400	55	-	-
Balancing chassis	1	150	60	Barrel cooling rate per second is increased by 50%.	This can only be selected if the robot meets the definition of a Balancing Standard Robot.

Chassis Type	Level	Maximum HP	Maximum Chassis Power Consumption (W)	Others	Remarks
	2	200	80	Barrel cooling rate per second is increased by 50%.	This can only be selected if the robot meets the definition of a Balancing Standard Robot.
	3	250	100	Barrel cooling rate per second is increased by 50%.	This can only be selected if the robot meets the definition of a Balancing Standard Robot.

Table 3-13 Attributes of Hero Robot Chassis

Chassis Type	Level	Maximum HP	Maximum Chassis Power Consumption (W)
Initial Status	0	150	50
Power-focused	1	200	70
	2	250	90
	3	300	120
HP-focused	1	250	55
	2	350	60
	3	450	65

Table 3-14 Attributes of 17mm Launching Mechanisms

Launching Mechanism Type	Level	Barrel Heat Limit	Barrel Cooling Value per Second	Initial Firing Speed Limit (m/s)
Initial Status	0	50	10	15

Burst-focused	1	150	15	15
	2	280	25	15
	3	400	35	15
Cooling-focused	1	50	40	15
	2	100	60	18
	3	150	80	18
Projectile speed-focused	1	50	10	30
	2	100	20	30
	3	150	30	30

Table 3-15 Attributes of 42mm Launching Mechanisms

Launching Mechanism Type	Level	Barrel Heat Limit	Barrel Cooling Value per Second	Initial Firing Speed Limit (m/s)
Initial Status	0	100	20	10
Burst-focused	1	200	40	10
	2	350	80	10
	3	500	120	10
Projectile speed-focused	1	100	20	16
	2	200	60	16
	3	300	100	16

3.10HP Recovery and Revival Mechanism



- If an Engineer Robot is defeated or ejected, its Engineer Rescue Card will be deactivated.
- If an Engineer Robot is separated from its Engineer Rescue Card, the Card will be deactivated for that round. The Engineer Robots of both red and blue teams are required to carry Engineer Rescue

Cards of their team colors. A sample image of the Engineer Rescue Card can be found in "Figure 2 - 45 Engineer Rescue Card".

Only the ground robot is qualified for HP recovery and revival, except for ejected robots.

3.10.1 HP Recovery Mechanism

- Engineer Robots: If an Engineer is not damaged for 30 seconds or after being revived from a defeat during a match, it will receive an HP recovery buff at 2% per second.
- Ground Robots: If an RFID Interaction Module Card of one's own team is detected at the Restoration Zone, the robot will receive an HP recovery buff of 5% per second.

3.10.2 Revival Mechanism

Defeated ground robots must complete the revival process in order to be revived. Different robots execute their revival process in different ways:

- If a Ground Robot detects an RFID Interaction Module Card at the Restoration Zone, the revival progress increases by 2 points per second.
- If a Standard or Hero Robot detects an Engineer Rescue Card carried by its own team's Engineer Robot, the revival progress increases by 1 point per second.
- During the automatic revival of an Engineer Robot (without detecting any RFID Interaction Module Card), the revival progress increases automatically by 1 point per second.

The length of revival processes for different robots on their first defeat are shown as follows:

Table 3-16 The length of revival processes for different robots on their first defeat

Robot Type	Revival process length
Standard Robot	10
Hero Robot	20
Engineer Robot	20

The revival process length for the same robot increases by 10 after each defeat.

A revived robot will maintain its level, performance points and experience points from before its defeat, and its HP will be restored to 20% of the Maximum HP. A revived robot will receive a 100% defense buff lasting for 10 seconds.

3.11 Mechanism Related to Sentry

3.11.1 HP Gain Mechanism

Sentry will receive HP Gain, which is calculated in real-time, from attacking ground robots of the enemy side. HP Gain for Sentry = HP Deduction caused by Sentry * 0.2.

3.11.2 Projectile Launching

The barrel heat of Sentry's two Launching Mechanisms shall be calculated separately. When the total number of projectiles launched by two Launching Mechanisms has reached 500, the Launching Mechanism will be powered off.

3.12 Aerial Robot-Related Mechanisms

3.12.1 Attack Deductions

3.12.1.1 Initial Firing Speed Exceeds the Limit

If the Referee System detects that the projectile of Aerial exceeds the Initial Firing Speed limit, the attack time of Aerial will be reduced. If the current attack time is about to expire, the time deduction will be applied to the next attack time. Attack time reductions will be accumulated in the case of multiple times of excess.

Assume Aerial's current Initial Firing Speed is V_1 and the Initial Firing Speed limit is 30 m/s, when the Referee System's Speed Monitor Module detects one 17mm projectile that its Initial Firing Speed V_1 exceeds 30 m/s, the Aerial's attack time will be reduced by: $t = 0.5 (V_1 - 30)^2$ s, keeping the integer.

3.12.1.2 Modules Going Offline

Air support will become unavailable if an important module of an Aerial Robot goes offline when it is not in a state of providing air support. If an important module goes offline during the attack time, the number of disposable projectiles of Aerial will be reduced. The correlation between the number of important module gone offline (M) and the number of projectiles reduced per second (N) is: $N = 25 * M$.

3.13 Dart Launching Mechanism

During each round, the gate of a Dart Launching Station has two opening opportunities, which the Aerial Gimbal

Operator can choose when to use.

After the start of a match, the operator will use the keyboard and mouse on the client interface to control the opening and closing of the gate and the launching of darts .



It takes around 5 seconds for the gate to open completely.

When the gate of the Dart Launching Station is fully opened, the Station's light indicator will light up and a prompt will appear on the client interface of the Referee System. The Aerial Gimbal Operator can then launch darts by controlling the Dart Launcher. The gate of a Dart Launching Station stays fully open for 15 seconds. When the gate of the Dart Launching Station is closed, the light indicator will go off and a prompt will appear on the client interface of the Referee System. The Aerial Gimbal Operator will no longer be able to launch darts. When a gate closes for the first time, the Dart Launching Station will enter a 15-second cooling period. The gate can only open for the second time after the end of the cooling period.

3.13.1 Detection Window Period

When the Dart Launching Station of one team detects a dart, the Dart Detection Module on the outpost or base of the other team will update the detection window period, for a period of 5 seconds. The launched dart needs to hit the Dart Detection Module within the detection window period, or the attack will be void.

3.13.2 Invalid Attacks

During the same open period of a gate, if the initial firing speed of a dart exceeds its limit, then all darts that have not hit their targets during this open period will not be able to inflict any effective damage.

For example: When an Aerial Gimbal Operator opens the gate of the Dart Launching Station for the first time, where it launches a Dart at 25 m/s hitting the Outpost, and then launches a Dart at 15 m/s hitting the Outpost again, the damage by both Darts on the Outpost will be invalid.

3.14 Logic of Mechanism Overlap

When a robot gains more than one buff of the same type, the maximum buff effect will be recorded. Buffs include attack, defense, HP recovery, and barrel heat cooling.

Example 1: For example, if an Engineer Robot has not suffered any damage for 30 seconds, it will recover its HP at 2% of its Maximum HP per second. If the Engineer Robot is in its team's HP Recovery and Revive Zone, its HP will recover at 5% of its Maximum HP per second.

Example 2: When a team has successfully activated the Large Power Rune, and the Hero Robot of the team fires a 42mm projectile from the Hero Robot Sniper Point and hits the triangular armor of the other team's Base, the damage inflicted is: $300 * 2.5 = 750$

3.15 Winning Criteria

The official matches of RMUC 2021 consist of the Group Stage and the Knockout Stage. The competition system for the Group Stage is BO2. Except for the Semifinals and the Championship Match which are BO5, the competition system for all other Knockout Stages is BO3.

The following are the criteria for winning in a single round:

1. When the Base of one team is destroyed, the round ends immediately and the team with the surviving Base wins.
2. When the duration of a round has elapsed and if the Bases of both teams have survived, the team with the higher Remaining HP is the winner.
3. If a round has ended and the remaining Base HP of both teams are the same and the Outposts of both teams have been destroyed, the team with the higher Remaining Sentry HP is the winner.
4. If a round has ended, and the remaining Base HP of both teams are the same, the team with the higher remaining Outpost HP is the winner.
5. If a round has ended and the Bases of both teams have not been destroyed and the remaining Outpost HP of both teams are the same, the team with the higher HP Deduction is the winner.
6. If a round has ended and the Bases of both teams have not been destroyed, the remaining Base, Outpost and Sentry HP of both teams are the same, and the total HP Deduction of both teams is the same, the team with the higher total Robot Remaining HP is the winner.
7. If neither team fulfills these criteria, the round is considered a draw. A draw in the Knockout Stage leads to an immediate tie-breaker round until a team wins.

3.15.1 Group Stage

The below shows the points for Group Stage:

Table 3-17 Points for Group Stage

Competition Format	Competition Result	Points	Remarks
BO2	2:0	3:0	Winner of two rounds gains 3 points
	1:1	1:1	One point for each team

	1:0	1:0	(draw for one round): The team winning one round gains 1 point
	0:0	0:0	(draw for two rounds): Each team gains 0 point

The ranking for the Group Stage is determined by the total points for each match. Teams are ranked based on the following order, in descending order of priority:

1. The team with the higher total match points ranks higher.
2. If the total match points of teams are the same, the team with the higher total Net Base HP from all rounds ranks higher.
3. If the total Net Base HP of teams are the same, the team with the higher total Net Outpost HP from all rounds ranks higher.
4. If the total Net Outpost HP of teams are the same, the team with the higher total Net Sentry HP from all rounds ranks higher.
5. If the total Net Sentry HP are the same, the team with the higher total HP Deduction ranks higher.
6. If two or more teams are still tied for the same place according to these criteria, the RMOC will arrange a playoff match on the basis of two extra rounds.

- HP Deduction: The total HP damage caused by one team's attack of the other team's robots, Outpost and Base calculated after the end of a round.
 - HP deducted as a result of exceeding the Initial Firing Speed limit, Barrel Heat limit and Maximum Chassis Power Consumption and of the Referee System going offline are not counted as HP Deduction.
 - HP deducted from violations and penalties (Level 2 to 5 Warnings) as executed by the referee will be counted as the enemy's HP Deduction.
 - The amount of HP deducted from a Virtual Shield from attacks will be counted as the enemy's HP Deduction.



- Net Base HP: The remaining HP of a team's Base subtracted by the remaining HP of the enemy's Base at the end of a round.
- Net Outpost HP: The remaining HP of a team's Outpost subtracted from the remaining HP of the enemy's Outpost at the end of a round.
- Net Sentry HP: The remaining HP of a team's Sentry subtracted from the remaining HP of the enemy's Sentry at the end of a round.
- Total Remaining HP: The total value of the remaining HP of a team's surviving robots at the end of

a round.

3.15.2 Knockout Stage

A team wins the Knockout Stage if it has won the most number of rounds: BO3 requires the winning of two rounds while BO5 requires the winning of three rounds.

4. Competition Process

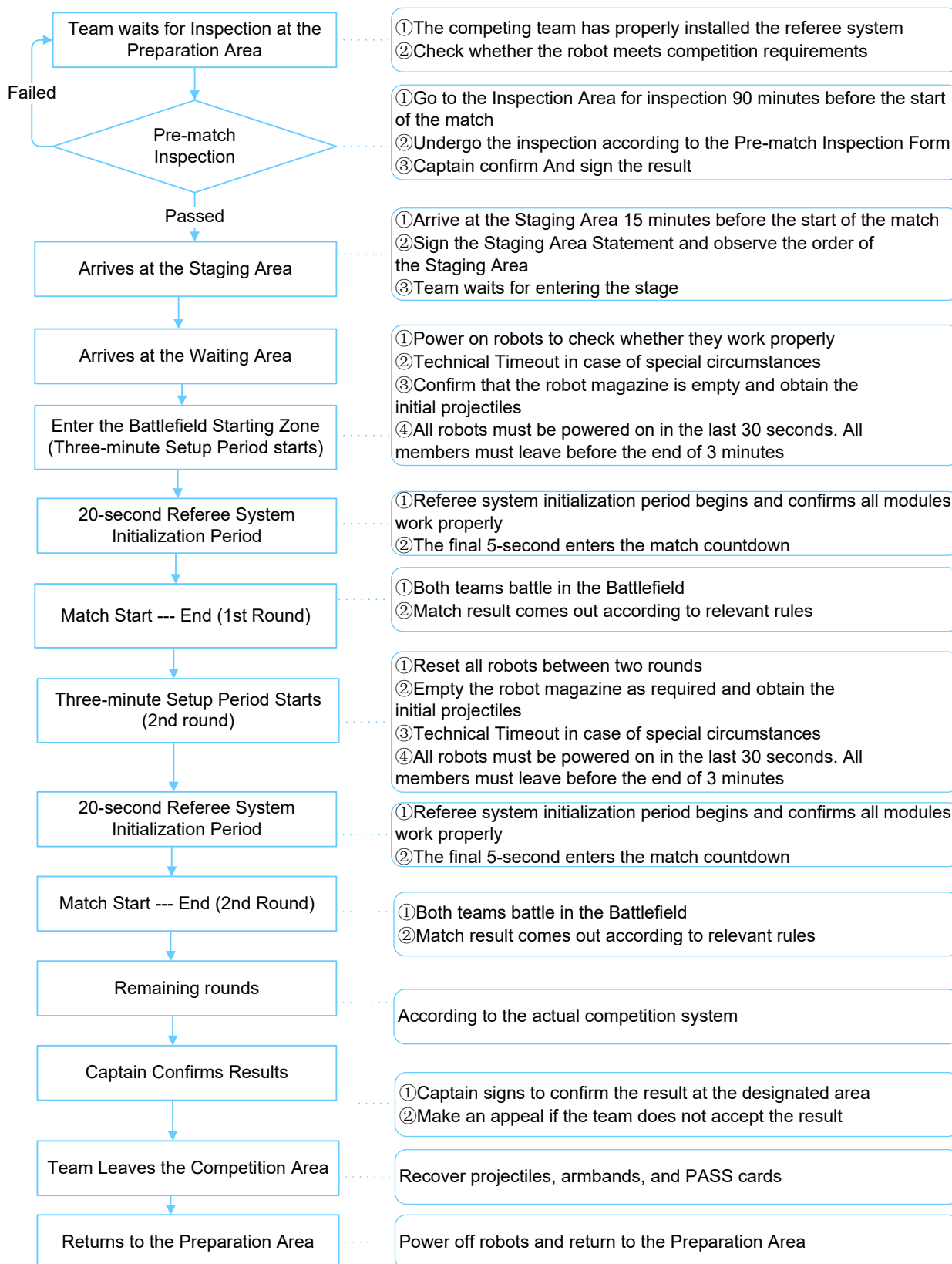

Figure 4-1 Process of a single match

4.1 Pre-Match Inspection

To ensure that robots meet the required standard specifications, each team must undergo Pre-match Inspection in the Inspection Area 90 minutes before the start of each match. For the requirements of the Pre-match Inspection, please refer to the [RoboMaster 2021 University Series Robot Building Specifications Manual](#). The inspection process is as follows:

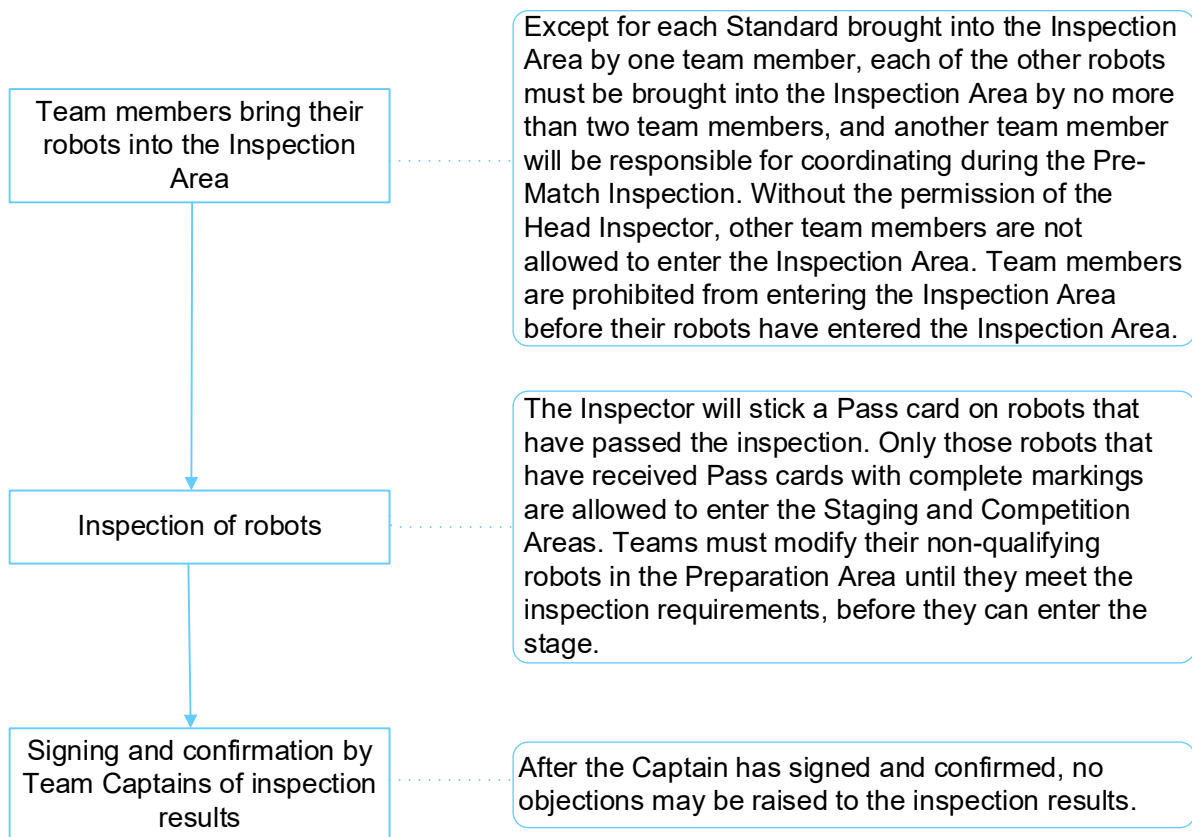

Figure 4-2 Process of Pre-Match Inspection

The rules regarding backup robots are as follows:

- Each team can have a maximum of two backup robots (one backup Dart Launcher is seen as one backup robot) for each match. A maximum of 4 backup darts are allowed in the BO2 and BO3 Competition Systems, while a maximum of 8 backup darts are allowed for the BO5 Competition System.
- Team members are required to declare the types of backup robots they are carrying during Pre-match Inspection. Backup Hero, Engineer and Sentry must be attached with armor stickers in the Inspection Area. If a backup Standard Robot is needed on the field, a Pit Crew Member must obtain the corresponding armor sticker promptly from the referee. The attachment of armor stickers must follow the requirements stated in the [RoboMaster 2021 University Series Robot Building Specification Manual](#).

- After passing the Pre-match Inspection, backup robots cannot be replaced without permission. During Mock Inspection, the RMOC will issue Referee Systems to backup robots that have passed Mock Inspection. Teams can borrow the Referee Systems for no more than two backup robots. Teams need to immediately return the Referee Systems of backup robots after finishing its competitions in the division.

4.2 Staging Area

Teams must arrive at the Staging Area 15 minutes before the match. Staff at the Staging Area will check the status of the participating robots and the information of the Pit Crew. The team needs to sign the Staging Area Statement after confirmation.

If any team needs to repair its robots after entering the Staging Area, it must obtain the permission of the staff at the Staging Area. Only when staff at the Staging Area has removed the Pass Card on the robot and the Staging Area Statement originally signed become invalidated can a robot leave the Staging Area for repair. When repair is finished, the robot needs to be brought back to the Inspection Area for another Pre-Match Inspection before re-entering the Staging Area, and the team Captain must sign a new Staging Area Statement. If a Staging Area Statement cannot be signed in time as a result of this delay, the robot will not be able to enter the match, and the team will bear its own consequences.

After leaving the Staging Area, the participating teams will enter the waiting area of the Competition Area to place their robots. When the previous match has ended and with the permission of the referee, the next pair of participating teams will wait at the entrance of the Battlefield with their robots for further instructions. After the referee has confirmed that both teams are ready, he or she will open the door and lead the team members into the Competition Area. The countdown for the Three-Minute Setup Period will begin when the door opens.

4.3 Three-Minute Setup Period



After the end of the second and fourth round of a BO5 match, both teams have ten minutes to work on their robots. When ten minutes run out, the Three-Minute Setup Period of the next round begins.

During the Three-Minute Setup Period, the Pit Crew will place robots on their respective initialization locations, check whether the Referee System is operating normally, clear the projectiles of robots whose Initial Projectile Quantity is zero, load initial projectiles on robots whose Initial Projectile Quantity is not zero, load darts into the Dart Launcher, and mount the Radar on the Radar Base. The Pit Crew Members may repair robots or perform replacements using equivalent parts. The referee may initiate an Official Technical Timeout at any time and perform immediate inspections on robots.



Equivalent parts: Standard modules or components having the same material, form and functions, for example motors of the same model and self-built friction wheel modules.

In the last 1 minute and 30 seconds of the Setup Period, the Operator should preferably be in the Operator Room to complete debugging for the keyboard and mouse (which can be brought by the team itself), and double-check that the robot controls and official equipment are operating normally.

The robot's control and official equipment are operating normally. If equipment in the Operator's Room cannot operate normally, the Operator must raise the issue before the Setup Period is left with 15 seconds. Otherwise, referee will not announce technical timeout. The tactical coach can make tactical deployments in the operator room before a match, but is not allowed to enter the Battlefield, and must leave the operator room before the end of the Three-Minute Setup Period. Besides the operator and tactical coach, no other Pit Crew Members are allowed to enter the operator room.

When the Setup Period is left with 30 seconds, all robots in the Battlefield must be powered up, and the staff in the Battlefield should leave the Competition Area in an orderly manner. Pit Crew Members must place the debugging remote controllers for the Sentry Robots, Dart System, Radar and Automatic Standard Robots in the designated area at the Battlefield entrance.

4.3.1 Official Technical Timeout

During the Three-Minute Setup Period, if the Referee System, equipment inside the Operator Room or other modules related to the Referee System experience any faults (for details see "Table 4-1 - Faults"), the Head Referee may announce an Official Technical Timeout and pause the setup countdown.

During an Official Technical Timeout, team members can only work with the staff in eliminating the relevant faults of the Referee System or other official equipment, and are not allowed to repair other faults. When the relevant fault of the of the Referee System or official equipment has been eliminated and the Head Referee has resumed the countdown, Pit Crew Members are required to follow the set procedures for the Three-Minute Setup Period and leave the Battlefield within the specified time.

Table 4-1 Descriptions of Technical Faults

Rule	Description
1	A fault occurs with the official equipment in the operator room, and any key competition component in the Battlefield experiences structural damage or functional irregularity.

Rule	Description
2	During the Three-Minute Setup Period of the first round, the Referee System module on a robot fails, for example where the robot is unable to transmit images back to the Operator's Room normally or connect to the Referee System server.
3	Other situations determined by the Chief Referee as requiring an Official Technical Timeout.

If the malfunction referred to in Rule 2 occurs during the Three-Minute Setup Period between rounds or during the 7-Minute Round, it will be categorized as "Regular Battle Damage", as it cannot be determined whether the malfunction was caused by the Referee System Module, a flaw in a robot's circuit or structural design, or robot combat from a previous match. Regular battle damage does not trigger an Official Technical Timeout, and the referee will provide a backup Referee System Module. Teams may request for a "Team Technical Timeout" to repair their robots.

4.3.2 Team Technical Timeout

If the mechanical structure of a robot, a software system, the keyboard or mouse in the Operator's Room or other equipment experiences any faults, the team Captain may make a request to the referee in the Battlefield or Operator's Room for "Team Technical Timeout" before the 15-second countdown in the Three-Minute Setup Period, and indicate the requested timeout length and reasons for the request. Once a Team Technical Timeout request has been made and conveyed to the Chief Referee, the Technical Timeout cannot be revoked or revised.

After a team's Technical Timeout has been allowed by the Head Referee, the Head Referee will inform both teams of the timeout regardless of which team requested the Team Technical Timeout. Pit Crew Members may enter the Battlefield to repair robots, while the members of both teams can only inspect, repair and commission their own robots in the initialization zones for the robots.

Even if the team did not enter the Battlefield or ended the Technical Timeout early, the opportunity used will still be the opportunity corresponding to the timeout length indicated by the team during its request. At this time, the Head Referee will continue the countdown of the Technical Timeout, or the Head Referee may end the Technical Timeout early after confirming that both teams are ready.

To ensure that subsequent matches begin on time, only one Team Technical Timeout is allowed in each Three-Minute Setup Period on a first-come-first-served basis. After the match, the Match Results Confirmation Form will state whether Technical Timeout opportunities have been used during the match. The type of Technical Timeout allowed is determined by the Chief Referee based on the request of the team. The team cannot dispute the type of Technical Timeout allowed, and the Technical Timeout process cannot be the basis for any appeal after the match.

A team cannot request for more Team Technical Timeout opportunities once they have been used up. The Team Technical Timeout arrangements for different competition stages are as follows:

Table 4-2 Team Technical Timeout Arrangement

Competition Stage	Arrangement
Group Stage	Two Technical Timeouts for 2 minutes each
Knockout Stage	One Technical Timeout for 3 minutes Technical Timeout opportunities not used in the Group Stage can be carried over to the Knockout Stage

4.4 Referee System Initialization Period

After the Three-Minute Setup Period, the match enters a 20-second Referee System Initialization Period. During the Initialization Period, the competition server will automatically detect the connection status of the client, the Referee System module status of the robot, the status of Battlefield Components and restore the HP of all robots, ensuring their HP are full when the match officially begins.

If in the first round of the match a robot experiences a technical fault with the Referee System, which causes the initialization countdown to stop, a maximum of two Pit Crew Members for the team are allowed to enter the Battlefield to inspect and solve the issue.

When the Referee System Initialization Period is left with 5 seconds, a clear countdown sound effect and live animation will be played. At this time, the keyboard connected to the computer in the Operator Room will be locked. When the countdown finishes and the keyboard unlocks, the match starts immediately.

4.5 Seven-Minute Round

During the 7-Minute Round, robots from both teams will engage in tactical combat on the Battlefield – the core Competition Area.

During the round, an Aerial Robot gains one opportunity to reload 500 rounds of projectiles for each time it is called to provide air support. The Pilot can request for projectile reload from the Pilot Referee. After the Referee has approved the reload, the Pilot has 30 seconds to reload the Aerial with projectiles. The 30-second projectile reloading period is calculated from when the Pilot opens the projectile reload window.

4.6 End of Competition

A round ends either when time has elapsed or one team has fulfilled the conditions for winning. When a round ends, the match immediately enters the Three-Minute Setup Period for the next round. Please refer to "3.14 - Winning Criteria" for details on the winning criteria. The match is over when a winner has emerged or all rounds have ended.

4.7 Match Results Confirmation

During a match, the referee will record on the Match Results Confirmation Form the penalties issued for each round, the key competition data at the end of the match, the winning teams, the use of Technical Timeout opportunities by the teams, and other relevant details. After the end of each match, team Captains need to be at the Referee Area to confirm the results.

Within five minutes after a match ends, Captains of both teams must confirm the match results by signing at the Referee Area. If a team Captain is not at the Referee Area within five minutes to sign and confirm the results and has not requested an appeal, it is deemed that the team agrees with the match results. Once a team Captain has signed and confirmed the results, no further appeals can be made. Please refer to "7 - Appeal" for details on the appeal process.

5. Violations and Penalties

To ensure the fairness and uphold discipline in the competition, teams and robots should strictly adhere to the competition rules. Referee will issue the appropriate penalty against any violation of rules. Any penalty issued before the start of a competition will be executed after the competition officially starts. Serious violations and all appeals in the competition will be publicized.

Penalties for the violations stated in this chapter will be determined by the Head Referee based on the actual situation. If any incident has occurred during the competition that affects the fairness of the competition but does not trigger any penalty or amount to a serious violation, the Head Referee shall decide on the issue of penalty based on the circumstances.

During the competition, the Chief Referee has the final right of interpretation on the Competition Rules. Any questions related to the Competition Rules must be referred to the Chief Referee only.

5.1 Penalty System

5.1.1 Forms of Penalties

During a match, the referee may issue penalties against participants and robots that have failed to comply with competition rules. The forms of penalties are as follows.

Table 5-1 Forms of Penalties

Forms of Penalties	Description
Automatic penalties by the Referee System	HP deductions as a result of a robot exceeding its parameter limits or a Referee System Module going offline. The HP deductions mentioned in "3.2 HP Deduction Mechanism", except those caused by attacks, are all automatic penalties by the Referee System.
Manual penalties through the Referee System	Penalties issued by the referee through the server against participants and robots for violation of rules.
Manual Penalties	Used in situations where penalties cannot be issued through the Referee System, for example issuing a verbal warning or disqualifying a team.

5.1.2 Violation Scores

Before the start of each round, each robot has a violation score of zero. A robot that is issued a Yellow Card during

the round will receive 2 violation points.

- When a robot has 4 violation points, a yellow exclamation point will appear on the robot's avatar on the client interface.
- When a robot has 6 violation points, a red exclamation point will appear on the robot's avatar on the client interface
- When a robot has 8 violation points, the robot will be ejected automatically from the current round of the match.

5.1.3 Types of Penalties

Five types of penalties may be issued during a match, as shown below:

Table 5-2 Types of penalties

Types of penalties	Description
Verbal Warning	A Verbal Warning is given to the offending party with no HP deducted.
Yellow Card	<ul style="list-style-type: none"> ● The operation interface of the offending Operator will be blocked for 5 seconds, while the operation interfaces of other Operators in the offending team will be blocked for 2 seconds. ● The Referee System automatically deducts 15% of the robot's Maximum HP, while the other surviving robots' Maximum HP is deducted by 5%. For each Yellow Card that is issued against the robot in the next 30 seconds, the deducted percentage will be twice that of the previous deduction for that robot, and 5% for the other surviving robots. <p>Example 1: An offending robot has a Maximum HP of 200 while the other robots in the team have a Maximum HP of 100. The offending robot is issued a Yellow Card each at the 15th, 25th and 58th second of a round. The HP deductions for the three Yellow Cards issued are as follows: The deducted HP for the offending robot are 30, 60 and 30. The deducted HP for the other robots are 5, 5 and 5.</p> <p>Example 2: An offending robot has a Maximum HP of 200 while the other robots in the team have a Maximum HP of 100. The offending robot is issued a Yellow Card each at the 15th, 25th and 40th second of a round. The HP deductions for the three Yellow Cards issued are as follows: The deducted HP for the offending robot are 30, 60 and 120. The deducted HP for the other robots are 5, 5 and 5.</p> <ul style="list-style-type: none"> ● The offending robot will receive 2 violation points.

Types of penalties	Description
Red Card (Ejection)	<ul style="list-style-type: none"> ● The offending robot is ejected: If this happens during a match, all of the robot's HP will be deducted automatically by the Referee System. If it is before a match, the robot will be barred from the match and must leave the Battlefield. ● Ejection of Pit Crew Members: Members ejected by the referee must immediately leave the Competition Area and no substitute Pit Crew Members are allowed in the remaining rounds of the match. The robot operated by the ejected Operator will be ejected for this round, and will not be allowed to enter or be substituted by other robots in all other rounds of the current match.
Forfeiture	<ul style="list-style-type: none"> ● If a Forfeiture is issued before the start of the match (not including the Three-Minute Setup Period), all the Pit Crew of the offending team must leave the Competition Area. The offending team's Base, Outpost and Sentry's HP will be deducted to zero, and the HP of the team's other robots will be full. The opposing team's Base and Outpost HP and their robots' HP remain full ● If a Forfeiture is issued during a match (including the Three-Minute Setup Period), the round will end immediately. The offending team's Base, Outpost and Sentry's HP are deducted to zero, and the team's other robots maintain their HP level at the end of the round. The HP of the opposing team's Base, Outpost and robots remain at the level when the round ended. ● If a Forfeiture is issued after a match, the offending team's Base, Outpost and Sentry's HP will be deducted to zero, and the team's other robots maintain their HP level from the end of the round. The HP of the opposing team's Base, Outpost and robots remain at the level when the round ended. ● If a Forfeiture is issued in a match (hereinafter referred to as "Match Forfeiture"), it applies to all rounds in the match, and the HP for each round shall be calculated according to the above descriptions.
Disqualification	<ul style="list-style-type: none"> ● The team member is disqualified from the current competition season. ● The team is disqualified from the current competition season, but its results so far in this season will be maintained as a reference for other teams.

If a robot's remaining HP is less than that needs to be deducted from penalty, this robot's HP reduces to 1.

5.1.4 Others

Apart from Forfeiture, no other penalties can form the basis for an appeal by a team. The Arbitration Commission may reject an appeal if it has been made on such a basis.

5.2 Penalty Rules

This chapter sets out the penalty rules and defines the relevant measures to be taken by the referee after a violation has occurred. Rules with a serial number R# are rules that must be adhered to by participating teams, team members and robots.

5.2.1 Staff

5.2.1.1 Participating Teams/Personnel

R1 Teams are required to meet the requirements in the [RoboMaster 2021 University Championship Participant Manual](#).

Penalties: The highest penalty that can be imposed on the offending party is disqualification.

R2 Teams must not set up their own wireless networks or communicate with team members using walkie-talkies in the relevant competition zones (including but not limited the Preparation Area, Inspection Area, Staging Area and Competition Area).

Penalties: The highest penalty that can be imposed on the offending party is disqualification.

R3 Except for emergency situations, teams must be present at the Inspection Area at least 90 minutes before the start of each match for Pre-match Inspection. The Captain needs to sign the Staging Area Statement 10 minutes before each match.

Penalties: Forfeiture of the current match.

R4 Team members must wear protective goggles when entering official designated areas such as the Preparation Area, Staging Area and Competition Area.

Penalties: The offender will be prevented from accessing the area.

R5 Team members must not turn on the power and commission or repair their robots in the Staging Area.

Penalties: Verbal Warning If the Verbal Warning is ineffective, the team shall be issued a Forfeiture of the match.

R6 Apart from Pit Crew Members who have entered the Staging Area and Competition Area beforehand due to

match-related reasons, no participants are allowed inside either area without special reasons.

Penalties: Verbal Warning If the Verbal Warning is ineffective, the offending team member shall be disqualified.

R7 Except projectiles preset in the Inspection Area, teams must not bring their own projectiles into the Inspection Area, Staging Area or Competition Area, and also must not take official projectiles away from the Competition Area.

Penalties: The staff confiscates the projectiles.

R8 Teams must not damage any official equipment (including but not limited to equipment in the Competition Area, Staging Area, Preparation Area and Inspection Area).

Penalties: Verbal Warning, and the offending party is required to pay compensation as per the price. The team may be issued a maximum penalty of disqualification, as judged based on the team's subjective intention and the impact of its violation on the competition process.

R9 Any participant who has entered the Staging Area and Competition Area for match-related reasons may not leave either area without permission.

Penalties: Any offending team member is forbidden from entering the Competition Area.

R10 After the end of a match, participants must clear the projectiles loaded in the robots at the Projectile Unloading Area.

Penalties: The offending robot will be detained in the Projectile Unloading Area, until its projectiles are cleared.

5.2.1.2 Pit Crew Members

- Pit Crew Members: Regular Members, Supervisors and Advisors that have been registered on the registration system and can enter the Staging Area and Competition Area, where only the Advisor is allowed to be the tactical coach.



- Captain Armband: Any Regular Member that wears the 'Captain' armband performs the Captain role during the match. The Captain is responsible for managing and controlling the team's participation in the competition process, confirming results, and requesting for Technical Timeouts, appeals, etc.

R11 Each team can have a maximum of 19 Pit Crew Members enter the Competition Area, of which 17 must be Regular Members (not including the tactical coach), along with a Supervisor and a tactical coach. One Pit Crew Member should wear the "Captain" armband and undertake the Captain's role.

Penalties: Verbal Warning If the Verbal Warning is ineffective, the team shall be issued a Forfeiture of the match.

R12 Pit Crew Members must meet identity requirements.

Penalties: Verbal Warning If the Verbal Warning is ineffective, the team shall be issued a Forfeiture of the match.

R13 Pit Crews must wear armbands which must not be covered. The "Captain" label of the Captain's armband must face the front.

Penalties: Verbal Warning

R14 Except for the Radar, team members are not allowed to power their self-prepared equipment using the power supply for official equipment in the Competition Area. However, they may bring their own power supply.

Penalties: Verbal Warning If the Verbal Warning is ineffective, offender shall be ejected from the Competition Area.

R15 Pit Crew Members entering the Competition Area must not communicate with anyone from the outside.

Penalties: Verbal Warning If the Verbal Warning is ineffective, the team shall be issued a Forfeiture of the match.

R16 Apart from the tactical coach and operator, other Pit Crew Members are not allowed to enter the operator room.

Penalties: Verbal Warning If the Verbal Warning is ineffective, the offender shall be issued a Red Card.

R17 The tactical coach must leave the operator room before the end of the Three-Minute Setup Period.

Penalties: Verbal Warning If the Verbal Warning is ineffective, the offender shall be issued a Red Card.

R18 After the end of the Three-Minute Setup Period, Pit Crew Members must return to the designated area outside the Battlefield. During the competition, Pit Crew Members are not allowed to leave the area without the permission of the referee.

Penalties: Verbal Warning If the Verbal Warning is ineffective, the offender shall be issued a Red Card.

R19 Pit Crew Members are not allowed to debug any Automatic Standard Robot, Sentry Robot, Radar and Dart System after the start of the Referee System Self Initialization Period.

Penalties: Forfeiture of the round.

R20 Pit Crew Members are not allowed to bring headsets into the Operator Room.

Penalties: Verbal Warning If the Verbal Warning is ineffective, the team shall be issued a Forfeiture of the match.

R21 During the Three-Minute Setup Period, team members may debug the Aerial Robot near the Landing Pad, but must not start the propeller.

Penalties: Verbal Warning If the Verbal Warning is ineffective, the offending team member and robot shall be

issued a Red Card.

R22 During the Three-Minute Setup Period, Pit Crew Members must ensure their robots are operating safely and will not cause harm to any person or equipment in the Competition Area.

Penalties: The offending party must bear the relevant responsibility.

R23 During an Official Technical Timeout, Pit Crew Members are not allowed to fix faults other than those in modules related to the Referee System.

Penalties: Verbal Warning If the Verbal Warning is ineffective, the offender shall be issued a Red Card.

5.2.1.3 Operator

R24 The use of one's own computers is prohibited in the Operator's Room.

Penalties: Forfeiture of the round.

R25 Operators must remain in the relevant Operator's Room during the Referee System Initialization Period and the Match, to operate the relevant computers, and must remain in position after a match has started, unless otherwise permitted by the referee.

Penalties: Verbal Warning If the Verbal Warning is ineffective, the offender shall be issued a Red Card. If the offender does not obey the penalty order, the offending team shall be issued a Forfeiture of the round.

R26 During the competition, each Operator must wear a headset and be equipped with no more than one remote controller.

Penalties: Verbal Warning If the Verbal Warning is ineffective, the offender and the robots operated by the offender shall be issued a Red Card. If the offender does not obey the penalty order, the offending team shall be issued a Forfeiture of the round.

R27 A Pilot that operates an Aerial Robot must pass the Pilot Assessment.

Penalties: The team is issued a Forfeiture for the round, and the offending team member is disqualified.

R28 The Pilot is required to wear a long-sleeved top and protective goggles A safety helmet needs to be worn when reloading projectiles.

Penalties: Forbidden from supplying projectiles for Aerial during the match.



- The safety helmet and pilot goggles are placed in the Pilot Room.
 - Since the helmet and headset cannot be worn at the same time, Pilot needs to take off the headset before wearing the helmet.
-

R29 Pilot can connect his phone to the remote controller to check the status of the Aerial, but he is not allowed to use the video transmitter function of the remote controller.

Penalties: Forfeiture of the round.

R30 A single projectile supply time for Pilot during the match cannot exceed 30 seconds.

Penalties: Verbal Warning, and the Pilot is required to return to the Pilot Room. If the Verbal Warning is ineffective, the offender shall be issued a Red Card.

5.2.2 Robots

5.2.2.1 General Rules

R31 Robots entering a match must pass Pre-match Inspection.

Penalties: Forfeiture of the round.

R32 In the first round of a match, the robots must meet the minimum battle team size.

Penalties: Forfeiture of the current match.

R33 Robots must be attached with armor stickers that meet the inspection specifications.

Penalties: If the violation happens before the start of a match, the offending robot will be barred from the match. If the violation happens during a match, the highest penalty that can be imposed on the offending party is a Red Card, based on the seriousness of the situation.

R34 When waiting in the Staging Area, team members are not allowed to bring robots out of the Staging Area without permission.

Penalties: Verbal Warning If the Verbal Warning is ineffective, the offending team member and robot shall be issued a Red Card.

R35 Robots must not carry or present safety issues including but not limited to short circuits, crashing, and falling to the ground. If a safety issue is present or has arisen, team members must execute the relevant operations in accordance with the referee's instructions.

Penalties: If it is before the start of a match, the Pit Crew need to resolve the safety issue as required by the referee, otherwise the offending robot will not be allowed onto the Battlefield. If it is during the competition, a Verbal Warning shall be issued. If the Verbal Warning is ineffective, a Red Card shall be issued against the offending team member or robot. Any incident involving serious safety hazards shall be handled by the Head Referee in accordance with "6 Irregularities".

R36 During the Three-Minute Setup Period and the Referee System Initialization Period, robots in the Battlefield are not allowed to leave their corresponding initialization zones.

Penalties: If it is during the Three-Minute Setup Period, a Verbal Warning shall be given. If the Verbal Warning

is ineffective, the highest penalty that can be imposed on the offending party is a Red Card. If it is during the Referee System Initialization Period, the Chief Referee shall issue a Yellow Card or Red Card against the offending team, judged based on the offending team's subjective intention and the impact of its violation on the competition.

R37 During the Three-Minute Setup Period, any projectile must be launched into the projectile clearance bag.

Penalties: Verbal Warning

R38 During the competition, the robot is not allowed to disintegrate into sub-robots or sub-systems connected by multiple flexible cables, and must not cast or launch their own parts.

Penalties: The offending robot will be issued a Red Card.

R39 During the competition, robots are not allowed to block any Armor Module with its body or transform beyond its maximum expansion size. Except for Engineer Robots, no robots may use any mobile Battlefield Component to block any of their own Armor Modules.



Mobile Battlefield Components: minerals, obstacle blocks.

Penalties: Warnings shall be issued against the offending party as judged based on their subjective intention. If the blocking was intentional, a Yellow Card will be issued along with a Verbal Warning. If the Verbal Warning is ineffective, a Red Card shall be issued. If the blocking was passive in nature, the offender will be issued a Yellow Card.

R40 During the Three-Minute Setup Period, the replacement modules or parts used on robots must meet the requirements for "equivalent parts" as stated in "4.3 Three-Minute Setup Period".

Penalties: Verbal Warning; if the warning is ineffective, the offending robot shall be issued a Red Card.

5.2.2.2 Ground Robots

R41 During the Three-Minute Setup Period for each round, the 17mm Launching Mechanisms of robots with an Initial Projectile Quantity of zero must be completely cleared of projectiles. Engineer Robots must be cleared of all 17mm projectiles.

Penalties: The offending team is issued a Red Card

R42 During the competition, Engineer Robots are not allowed to use additional lights except for procuring minerals.

Penalties: Verbal Warning If the Verbal Warning is ineffective, the offending team shall be issued a Yellow Card.

R43 During a match, each team can have no more than one robot installed with a motorized 17mm Launching

Mechanism.

Penalties: During the Three-Minute Setup Period, if any team in the Battlefield has multiple robots installed with mobile 17mm Launching Mechanisms, the Pit Crew Members must remove the excess robots from the Battlefield as required by the rules. If the Initialization Period has commenced, the Referee System shall automatically retain the robot with the smallest serial number while issuing a Red Card against all the remaining offending robots.

For example: if a team's Hero and Standard Robots are found to be installed with a mobile 17mm Launching Mechanism during the Initialization Period, the Referee System's server will automatically eject the Standard Robot.

R44 Standard Robots to be fitted with a balancing chassis must meet the definition of a Balancing Standard Robot during the competition. See "1.3.2.3 Standard Robot".

Penalties: Warnings shall be issued against the offending party based on the length of the violation. If it exceeds 3 seconds, a first Yellow Card is issued. Thereafter, each 10 seconds will incur a further Yellow Card. This carries on until the robot is depleted.

5.2.2.3 Aerial Robot

R45 An Aerial Robot is not allowed to start its propellers during the Three-Minute Setup Period.

Penalties: Verbal Warning If the Verbal Warning is ineffective, the offending robot will be issued a Red Card.



If the team's Dart Launching System or Radar enters the stage, the Aerial Gimbal Operator can stay in the Operator Room.

R46 The Safety Rope of Aerial must be hooked onto the rigid ring.

Penalties: The offending robot will be issued a Red Card.

R47 During the competition, the distance between the lowest point of an Aerial Robot and the Battlefield ground must not be less than 1500 mm, and no part of the 17mm Speed Detection Module carried by the Aerial Robot's gimbal Launching Mechanism can exceed the highest point of the Perimeter Wall of the Flight Zone

Penalties: A Gesture or Verbal Warning is given to the pilot, to remind him or her to adjust the flight altitude. If a warning is ineffective, the offending robot shall be issued a Red Card and forbidden from entering any rounds in the same match.

R48 During the competition, Aerial is forbidden from flying outside the Competition Area.

Penalties: The offending robot is issued a Red Card and forbidden from entering any rounds in the same match.

R49 If Aerial experiences technical faults, or is damaged due to the unreasonable design of the propulsion system

or power supply system during the competition, it must be checked by the referee and must be cleared by the Head Referee as hazard-free before it can be allowed to return to the match.

Penalties: The offending robot is issued a Red Card and forbidden from entering any rounds in the same match.

5.2.3 Interaction

5.2.3.1 Interaction between Robots

R50 No robot may use any part of its body to strike an enemy robot, except where a destroyed robot is obstructing a path and needs to be slowly pushed away.

-
- In any collision between an Aerial Robot and Ground Robot, the Aerial Robot will be deemed the offender.
 -  ● In any collision between a Sentry Robot and Ground Robot, the Ground Robot will be deemed the offender.
 - In any collision between two Ground Robots, the offender will be the robot deemed by the referee as the initiator.
-

Penalties: Warnings shall be issued against the offending party as judged based on their subjective intention and the degree of collision.

Table 5-3 Penalties for Collision

Violation Level	Description
Yellow Card	Actively causing high-speed front collision, active pushing causing the other team's robot to move, or impeding the normal movement of the other team's robot
Red Card	Actively, maliciously and repeatedly causing high-speed front collision, active and prolonged pushing causing the other team's robot to move over a fairly long distance, seriously impeding the normal movement of the other team's robot, or securing a major advantage unfairly by means of aggressive collision.

R51 A robot must not stick itself to any enemy robot through active interference, blocking or collision.

Penalties: Warnings shall be issued against the offending party based on the length of the violation. If it exceeds 10 seconds, a first Yellow Card is issued. Thereafter, each 20 seconds will incur a further Yellow Card. This carries on until the robot is depleted. Regardless of whether the offending robot is surviving, if the violation goes on for longer than 90 seconds, the offending team will be issued a Forfeiture for that round.

R52 A team's robots must not prevent an enemy robot from engage in rescue operations through acts such as blocking and collision.

- Any action that meets the following criteria constitutes a rescue.
 - The robot being rescued has been defeated.
 - The mechanisms of the rescuing robot and the robot being rescued must be connected, i.e. the rescuing robot remains connected to the robot being rescued whichever direction the rescuing robot moves towards.
 - The rescuing robot and the robot being rescued are moving towards their team's Restoration Zone (through the shortest route on the Battlefield)



Any action other than the above is not considered a rescue. The act of pushing by any robot is not considered a rescue.

- A rescuing robot that is moving towards its team's Restoration Zone during a rescue has priority passage and cannot be blocked.
-

Penalties: Warnings shall be issued against the offending party based on the length of the violation. If it exceeds 3 seconds, a first Yellow Card is issued. Thereafter, each 10 seconds will incur a further Yellow Card. This carries on until the robot is depleted.

R53 No robot may attack the Aerial Robot, Dart Launcher and Radar of the opposing team.

Penalties: The offending robot will be issued a Red Card.

R54 No robot may interfere with the regular projectile reload, HP recovery or revival of an enemy robot.

Penalties: The offending team is issued a Yellow Card.

5.2.3.2 Interaction between Robots and Battlefield Components

In order to ensure the fairness of the competition and that robots in the Battlefield are able to receive buffs or reloads effectively, multiple penalty zones have been set up in the Battlefield where the robots of one or both teams are forbidden from entering, as shown below.

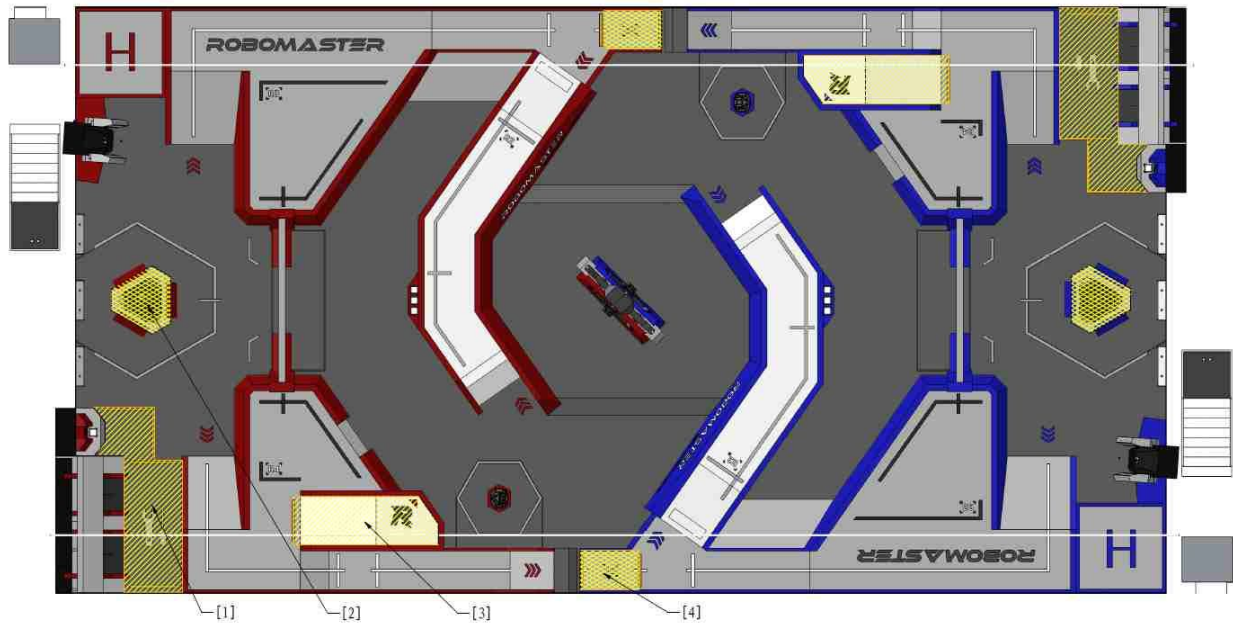

- | | | | |
|---------------------------|-----------------------|--|-----------------------|
| [1] Supplier Penalty Zone | [2] Base Penalty Zone | [3] Power Rune Activation Point Penalty Zone | [4] Road Penalty Zone |
|---------------------------|-----------------------|--|-----------------------|

Figure 5-1 Base Penalty Zone

R55 Robots are forbidden from entering the Base Penalty Zone or Launch Ramp Penalty Zone.

Penalties: Warnings shall be issued against the offending party based on how long the robot remained in the Penalty Zone and the impact of the violation. If it exceeds 3 seconds, a first Yellow Card is issued. Thereafter, each 10 seconds will incur a further Yellow Card. This carries on until the robot is depleted. An offending robot that causes serious damage to an enemy robot by remaining in a Penalty Zone will be issued a Red Card.

R56 The robots of one team are forbidden from entering the Supplier Penalty Zone and Power Rune Activation Point Penalty Zone, and must not cause any interference with or hindrance to the entry of the other team's robots into the Supplier Penalty Zone and Power Rune Activation Point Penalty Zone.

Penalties: Warnings shall be issued against the offending party based on how long the robot remained in the Penalty Zone and the impact of the violation. If it exceeds 3 seconds, a first Yellow Card is issued. Thereafter, each 5 seconds will incur a further Yellow Card. This carries on until the robot is depleted.

R57 A robot that is in the Starting Zone Buff Point and Outpost Buff Point of its team must ensure the long edge of the obstacle block it carries is not at an angle larger than 30 degrees from the ground.



Any angle judged by the naked eye may contain margins of error.

Penalties: The offending team is issued a Yellow Card.

R58 Robots must not place mobile Battlefield Components in the Launch Ramp, Supplier and Power Rune Activation Point Penalty Zones.

Penalties: The offending team is issued a Yellow Card.

R59 Participating robots are only allowed to use projectiles provided officially by the RMOC.

Penalties: Verbal Warning If the Verbal Warning is ineffective, the highest penalty that can be imposed on the offending party is disqualification, based on the seriousness of the situation.

R60 During the 7-Minute round, no robot is allowed to obtain projectiles from any other sources besides the Official Projectile Supplier and the Engineer Robot.

Penalties: The offending robot will be issued a Red Card.

R61 An Engineer Robot is not allowed to grab more than one mineral at a time or grab an mineral that has not been fully released.

Penalties: The offending robot will be issued a Red Card.

R62 During the competition, no robot is allowed to move any Battlefield Components, damage any core component in the Battlefield using its body, or interfere with the normal functions of the core components.



Core components: Including but not limited to the Dart Launching Station, Exchange Station, Official Projectile Supplier, Base and Outpost

Penalties: The highest penalty that can be imposed on an offending party is Forfeiture for that match.

5.3 Serious Violations

The following actions are considered serious violations of rules. The highest penalty a referee may impose on an offending party for serious violations is disqualification.

Table 5-4 Categories of Serious Violations

Rule	Robot Type
1.	Violating rules mentioned in this chapter and refusing to accept penalties, for example a Pit Crew Member interfering with the regular work process of a referee.
2.	Tampering with or damaging the Referee System, or interfering with any detecting function of the Referee System through technical means.
3.	Installing explosives or other prohibited materials on robots
4.	A situation has occurred in the Competition Area that violates Pre-Match Inspection requirements

Rule	Robot Type
5.	A team member deliberately damaging the opponent's robots, Battlefield Components and related equipment.
6.	Causing delays deliberately or refusing to immediately leave the Competition Area after a match has ended, thereby disrupting the schedule of the competition
7.	A team member using robots to collide into or attack other people deliberately, putting themselves and other people at risk of injury
8.	Serious verbal or physical conflicts between team members and the staff of the RMOC, other participating teams, audience, etc.
9.	A team member's refusal to cooperate, deliberate delay or provision of false materials and information during the RMCO's handling of an appeal request.
10.	In respect of any violation of local laws and regulations occurring inside the Competition Area, Audience Area, dormitories or other relevant competition zones during the competition, the RMOC, apart from issuing the most severe penalty of "disqualification", will fully cooperate with the relevant authorities to pursue appropriate legal actions against the offenders.
11.	Any other violation that seriously affects the progress of the matches, goes against the spirit of fair competition, or is deemed as serious in nature by the Chief Referee.

6. Irregularities

 There may be some degree of delay in the referee's issuance of a manual penalty and handling of an irregularity. If the competition's outcome has been seriously affected, the Chief Referee will determine the final penalty based on the actual circumstances.

If any of the following anomalies occur during the competition, it shall be handled according to the corresponding process, to which both teams cannot object. The handling process is as follows:

- When a robot safety hazard or irregularity in a robot has occurred on the Battlefield, such as battery explosion, Aerial breaking an Aerial Safety Rope, stadium power outage, explosion of a compressed gas cylinder, or interpersonal conflict), the Chief Referee will notify both teams' operators after discovering and confirming the emergency, and eject all robots through the Referee System. The result of the round will be invalidated. The round will restart after the safety hazard or exception has been eliminated.
- If non-key Battlefield Components are damaged during a match (damage to the ground rubber surface, ground lighting, or Base lighting), which do not affect the fairness of the match, the match will proceed as usual.
- If key Battlefield Components experience logical or structural faults, for example where the network connections are disrupted causing a robot to go offline, no buff is gained after a Power Rune is hit, or a Battlefield Component does not operate normally, the referee will solve the problem manually through the Referee System. If the problem cannot be solved manually, the referee will notify the operators of both teams and eject all robots. The round of the match is ended immediately and its results are invalidated. The round will restart after the issue has been solved.
- During a match, if the fairness of a match has been affected by the malfunction or structural damage of a key Battlefield Component, and the Chief Referee did not confirm the situation and end the competition in time, causing a round that should have been ended to continue and thereby producing a winner, A rematch will be required and the results of the round will be invalidated, after an appeal has been made or the Chief Referee has made a determination to that effect after the end of the round.
- In the case of a serious violation that would clearly have triggered a penalty of forfeiture, and the Chief Referee did not confirm and execute it in time, the results of the round will be invalidated after an appeal has been made or the Chief Referee has made a determination to that effect after the end of the round, and the offending party will be issued a forfeiture.

7. Appeals

Every team has one appeal opportunity during the Regional Competition and one during the Final Tournament. Appeal opportunities cannot be used cumulatively across competitions. If an appeal is successful, the team involved retains its right to appeal again in future matches. If it is unsuccessful, the team will have exhausted its one opportunity to appeal. When a team has exhausted its opportunity to appeal, the RMOC will no longer accept any appeal from the team. When processing an appeal, an Arbitration Commission will be formed by the Chief Referee and heads of the RMOC. The Arbitration Commission has the final right of interpretation on all appeal decisions.

7.1 Appeal Process

Teams lodging an appeal must follow the procedure below:

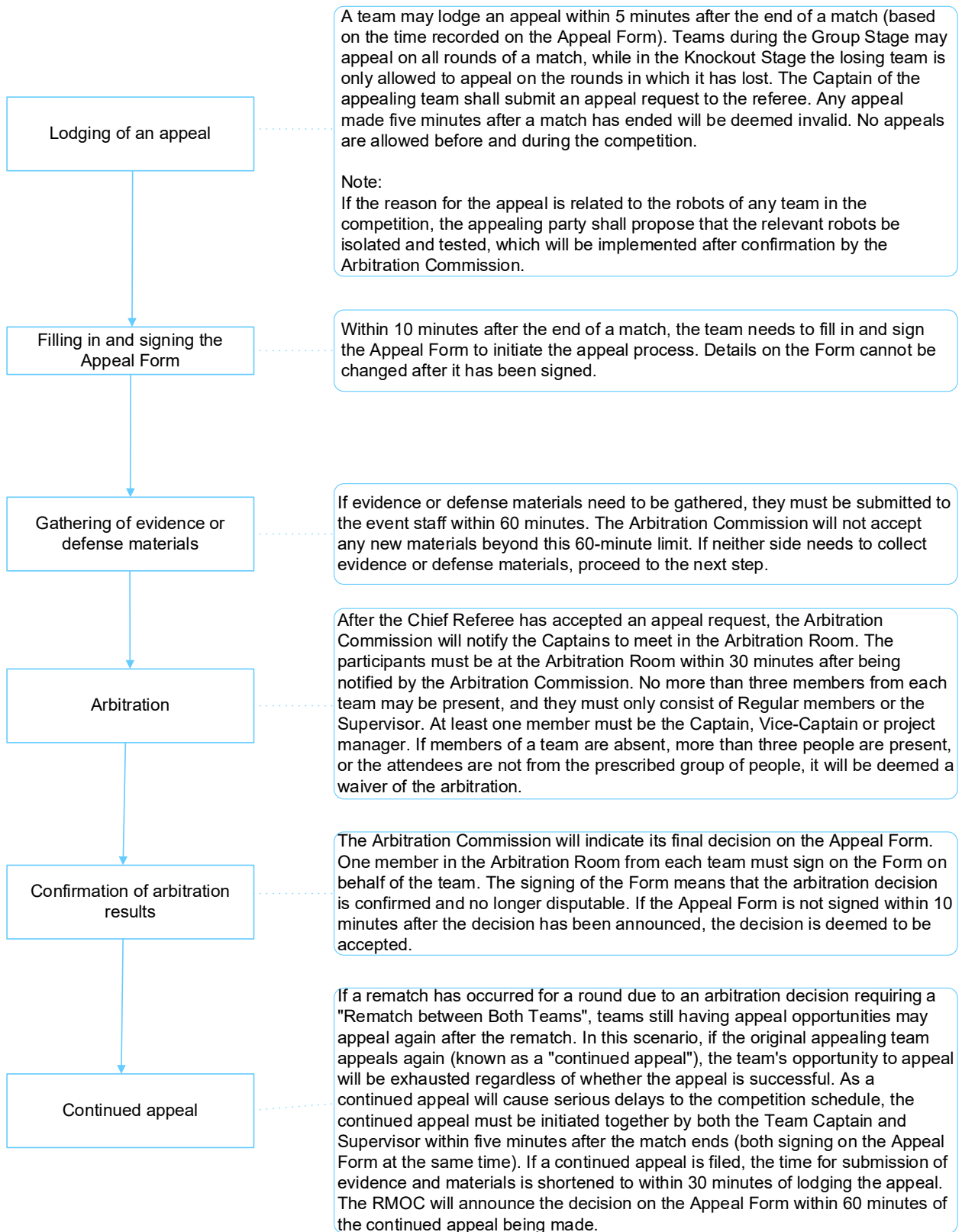

A team may lodge an appeal within 5 minutes after the end of a match (based on the time recorded on the Appeal Form). Teams during the Group Stage may appeal on all rounds of a match, while in the Knockout Stage the losing team is only allowed to appeal on the rounds in which it has lost. The Captain of the appealing team shall submit an appeal request to the referee. Any appeal made five minutes after a match has ended will be deemed invalid. No appeals are allowed before and during the competition.

Note:
If the reason for the appeal is related to the robots of any team in the competition, the appealing party shall propose that the relevant robots be isolated and tested, which will be implemented after confirmation by the Arbitration Commission.

Within 10 minutes after the end of a match, the team needs to fill in and sign the Appeal Form to initiate the appeal process. Details on the Form cannot be changed after it has been signed.

If evidence or defense materials need to be gathered, they must be submitted to the event staff within 60 minutes. The Arbitration Commission will not accept any new materials beyond this 60-minute limit. If neither side needs to collect evidence or defense materials, proceed to the next step.

After the Chief Referee has accepted an appeal request, the Arbitration Commission will notify the Captains to meet in the Arbitration Room. The participants must be at the Arbitration Room within 30 minutes after being notified by the Arbitration Commission. No more than three members from each team may be present, and they must only consist of Regular members or the Supervisor. At least one member must be the Captain, Vice-Captain or project manager. If members of a team are absent, more than three people are present, or the attendees are not from the prescribed group of people, it will be deemed a waiver of the arbitration.

The Arbitration Commission will indicate its final decision on the Appeal Form. One member in the Arbitration Room from each team must sign on the Form on behalf of the team. The signing of the Form means that the arbitration decision is confirmed and no longer disputable. If the Appeal Form is not signed within 10 minutes after the decision has been announced, the decision is deemed to be accepted.

If a rematch has occurred for a round due to an arbitration decision requiring a "Rematch between Both Teams", teams still having appeal opportunities may appeal again after the rematch. In this scenario, if the original appealing team appeals again (known as a "continued appeal"), the team's opportunity to appeal will be exhausted regardless of whether the appeal is successful. As a continued appeal will cause serious delays to the competition schedule, the continued appeal must be initiated together by both the Team Captain and Supervisor within five minutes after the match ends (both signing on the Appeal Form at the same time). If a continued appeal is filed, the time for submission of evidence and materials is shortened to within 30 minutes of lodging the appeal. The RMOC will announce the decision on the Appeal Form within 60 minutes of the continued appeal being made.

Figure 7-1 Process of an appeal

7.2 Appeal Materials

Appeal materials submitted by teams must follow the below specifications:

- **Material type:** Only materials stored on a USB flash drive and the robots themselves will be accepted as appeal materials. Materials submitted in other forms will not be accepted by the Arbitration Commission.
- **USB flash drives:** The edited video (the video materials should be prepared by the team itself) and the text files for the appeal should be placed according to the directory.
- **Material format:** No video may exceed one minute in length or 100MB in size. The name of the video must indicate the specific match, the round of the match and the time it was taken (rounded to minutes). The videos should be compatible with the latest version of Windows Media Player; the photos must be in JPG format; and the text documents must be in PDF format and not exceed 1,000 words in length.
- **Material naming:** The file name of each video and photo must be within 30 Chinese characters.
- **Text requirements:** One text file can only correspond to one video or a photo, which must be indicated in the text. Text files only need to explain the violations reflected in the corresponding materials.
- **Robot evidence:** The Arbitration Commission has the authority to isolate any relevant robot from both teams after an appeal has been made. These robots will be returned to the teams at the latest when the arbitration decision is announced.

7.3 Appeal Decision

The arbitration decisions that can be made include: Maintaining the original match results; a forfeiture issued against the respondent; a rematch between both teams. Teams may not appeal against the decision made by the Arbitration Commission.

If the Arbitration Committee requires both teams to hold a rematch, the Organizing Committee will inform both teams of the rematch time when the arbitration decision is announced. If both teams refuse to hold a rematch, the appeal is deemed failed and the original match results are maintained. If only one team refuses the rematch, the refusing team is deemed to have forfeited and lost the round.



Provided it does not affect the schedule of the entire competition, the rematch will in principle be held on the same day after all the other matches.

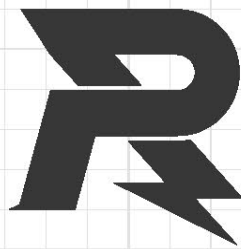

E-mail: robomaster@dji.com

Forum: bbs.robomaster.com

Website: www.robomaster.com

Tel: +86 (0)755 36383255 (GTC+8, 10:30AM-7:30PM, Monday to Friday)

Address: Room 202, Floor 2, Integrated Circuit Design & Application Industrial Park, No. 1089,
Chaguang Road, Xili County, Nanshan District, Shenzhen City, Guangdong Province, China